

COMPONENTS DIAGRAM: KRISS VECTOR SMG ALPINE LIMITED EDITION

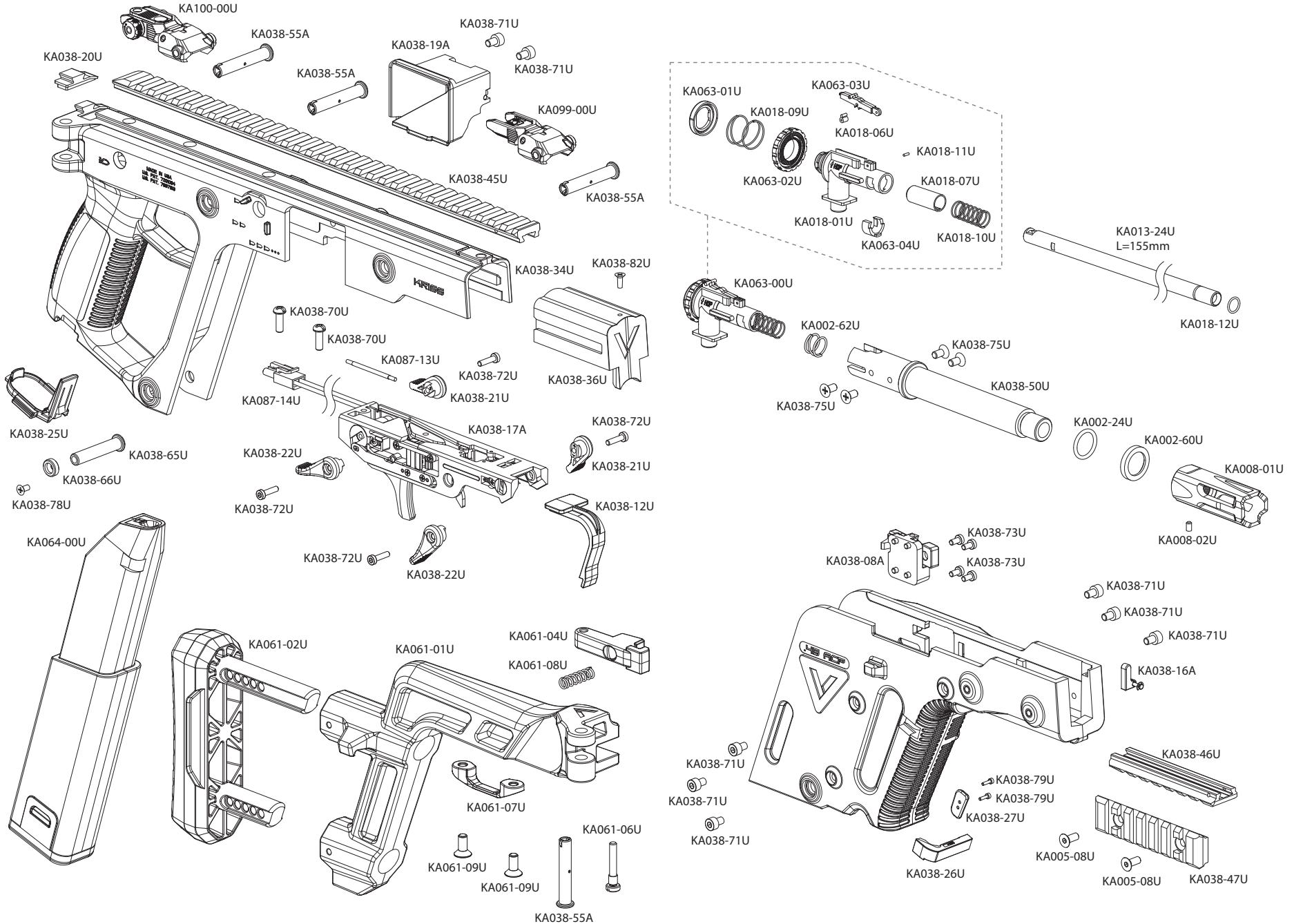

COMPONENTS DIAGRAM: KRISS VECTOR SMG GEARBOX

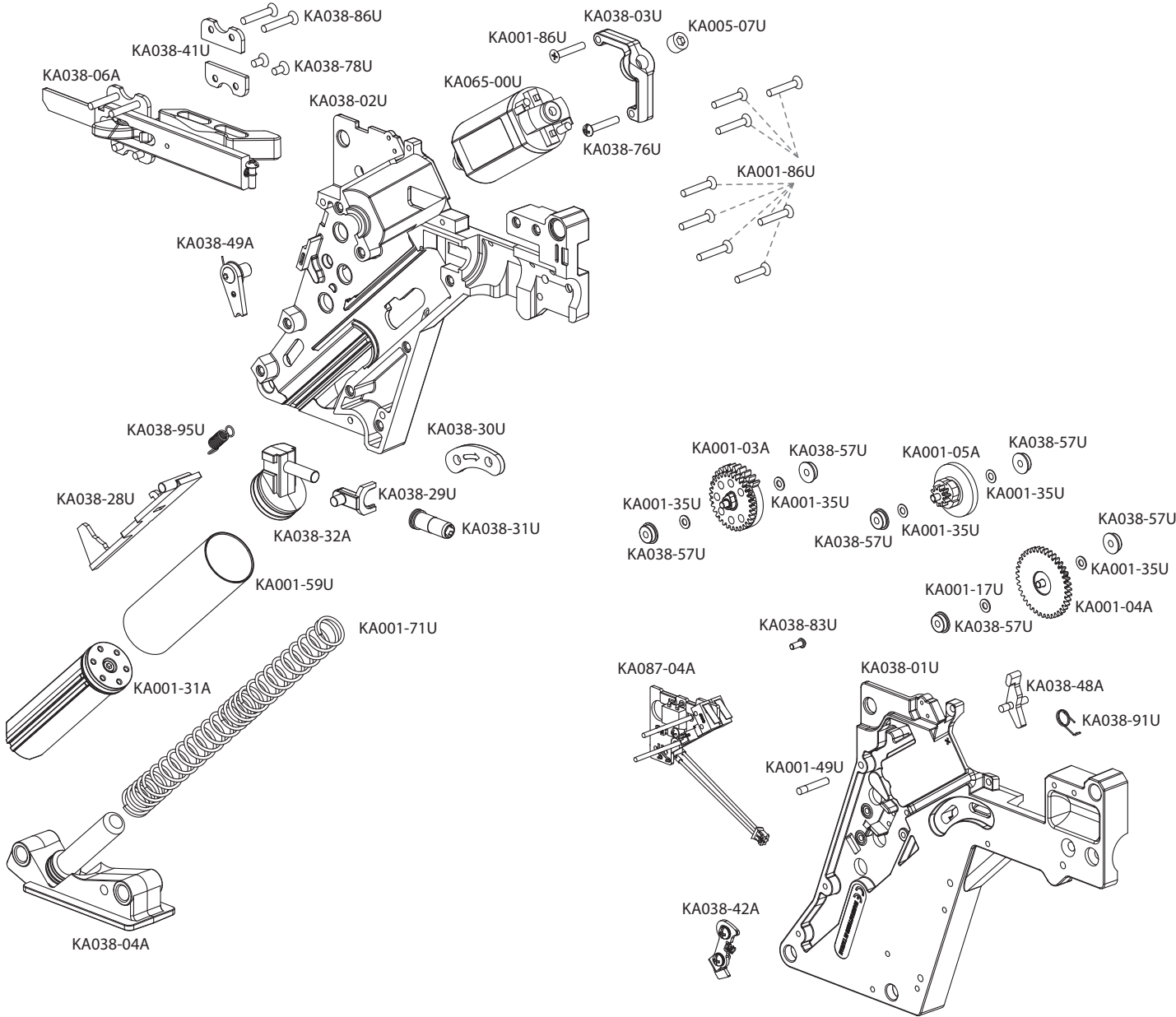

COMPONENTS LIST: KRISS VECTOR SMG ALPINE LIMITED EDITION



PART #	NAME					
KA001-03A	SECTOR GEAR	KA028-02U	CASTLE NUT	KA038-48A	ANTI-REVERSE LATCH (ARL) ASSEMBLY	
KA001-04A	SPUR GEAR	KA038-01U	GEARBOX PANEL (RIGHT)	KA038-49A	ANTI-SECTOR GEAR REVERSE LEVER (ASGRL) ASSEMBLY	
KA001-05A	BEVEL GEAR	KA038-02U	GEARBOX PANEL (LEFT)	KA038-55A	BREAK DOWN PIN ASSEMBLY	
KA001-17U	PISTON HEAD SHIM	KA038-03U	MOTOR BRACKET	KA038-63U	EXTENDED GRIP COVER	
KA001-31A	PISTON ASSEMBLY	KA038-04A	SPRING PLATE	KA038-65U	SECURITY PIN	
KA001-35U	SHIM	KA038-06A	CHARGING HANDLE ASSEMBLY	KA038-66U	SECURITY WASHER	
KA001-49U	ANTI-REVERSE LATCH PIN	KA038-08A	BOLT CATCH BLOCK ASSEMBLY	KA038-70U	TRIGGER GROUP HOUSING SCREWS	
KA001-59U	CYLINDER (TYPE 1)	KA038-12U	TRIGGER COVER	KA038-72U	SELECTOR SCREWS (4)	
KA001-61U	STEEL BUSHING	KA038-16A	BOLT LOCK TRIGGER ASSEMBLY	KA038-73U	BOLT LOCK BLOCK SCREWS (4)	
KA001-71U	MAIN SPRING (M120)	KA038-17A	TRIGGER HOUSING ASSEMBLY (TAMIYA)	KA038-75U	BARREL MOUNTING SCREW	
KA001-86U	GEARBOX SHELL SCREW (LONG)(11)	KA038-17B	TRIGGER HOUSING ASSEMBLY (T-PLUG)	KA038-78U	CHARGING HANDLE COVER SCREW (3)	
KA002-24U	CRUSH WASHER O-RING	KA038-19A	EJECTION PORT ASSEMBLY	KA038-79U	MAGAZINE RELEASE SCREW (2)	
KA002-49U	LOCKING SCREW	KA038-21U	SAFETY/SELECTOR LEVER (LEFT)	KA038-82U	NOSE CAP SCREW	
KA002-60U	CRUSH WASHER	KA038-22U	SAFETY/SELECTOR LEVER (RIGHT)	KA038-83U	SELECTOR BOARD SCREW	
KA002-62U	HOP-UP OUTER TENSION SPRING	KA038-25U	GRIP COVER	KA038-86U	CHARGING SLIDER SPRING	
KA005-07U	RETENSION SCREW	KA038-26U	MAGAZINE RELEASE BUTTON	KA038-91U	ANTI-REVERSE LATCH SPRING (ARL SPRING)	
KA005-08U	SIDE RAIL SCREW	KA038-27U	MAGAZINE RELEASE	KA038-95U	TAPPET PLATE SPRING	
KA008-01U-OP	FLASH HIDER (ORANGE PLASTIC)	KA038-28U	TAPPET PLATE	KA041-01U	VECTOR HAND STOP	
KA008-02U	SET SCREW	KA038-29U	TAPPET PLATE ARM	KA041-03U	VECTOR HAND STOP PIN	
KA012-33U	RECEIVER PANEL TOP SCREW	KA038-30U	TAPPET PLATE LINK	KA063-00A	HOP-UP ASSEMBLY	
KA013-24U	INNER BARREL (155MM)	KA038-31U	NOZZLE	KA063-01U	HOPUP DIAL RETAINER	
KA018-01U	HOP CHAMBER	KA038-32A	CYLINDER HEAD BASE	KA063-02U	HOPUP DIAL	
KA018-06U	NUB	KA038-35U	LOWER RECIEVER HOUSING	KA063-03U	HOPUP ARM	
KA018-07U	BUCKING	KA038-36U	NOSE CAP (ALPINE)	KA063-04U	BARREL CLIP	
KA018-09U	ADJUSTMENT SPRING	KA038-41U	CHARGING HANDLE COVER (2)	KA064-00U	VECTOR MAGAZINE (LONG)	
KA018-10U	HOP UP TENSION SPRING	KA038-42A	DISCONNECTOR ASSEMBLY	KA065-00U	MOTOR	
KA018-11U	ADJUSTMENT LEVER PIN			KA073-00U	KRISS® DS150 STOCK	
KA018-12U	FRONT BARREL O-RING					
					KA081-04U	M-LOK HAND GUARD SCREW
					KA085-23U	BODY SCREW
					KA087-04A	SELECTOR BOARD ASSEMBLY
					KA087-13U	SAFETY PLATE RETAINER
					KA092-01U	BUFFER TUBE
					KA099-00U	FRONT SIGHT
					KA100-00U	REAR SIGHT
					K140-01U	KRISS VECTOR MK5 MODULAR HAND GUARD
					K140-02U	BOTTOM RAIL (LONG)
					K140-03U	SIDE RAIL (SHORT)
					KA157-02U	UPPER RECEIVER HOUSING (ALPINE)
					KA185-00U	MAGAZINE (SHORT)
					KA212-01U	OUTER BARREL
					12702001	TOP RAIL