



KRYTAC®

OWNER'S MANUAL

KRISS®

VECTOR SMG

ALPINE

LIMITED EDITION

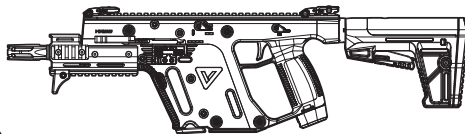

TABLE OF CONTENTS

Safety Rules	2
Specifications	4
Velocity and Energy Output Chart	5
Package content.....	5
Loading the Magazine	6
Loading the Airsoft Gun.....	6
Safety Selector Switch.....	7
Fire Select	7
DS150 Stock.....	7
Battery Installation	8
Hop-Up System	9
Clearing Jammed BBs.....	10
Disassembly	11
Assembly	12
Main Spring Access.....	13
Cleaning	14
Operating Under Harsh Conditions	15
Hearing Protection Requirement	15
Contact Information	15
Trouble Shooting Guide.....	16
Component Diagrams and Lists	17



WARNING

THIS PRODUCT IS NOT INTENDED FOR USE BY UNTRAINED PERSONS (INCLUDING CHILDREN) WITH OR WITHOUT PHYSICAL OR MENTAL HANDICAPS. THESE HANDICAPS INCLUDE REDUCED PHYSICAL, SENSORY OR MENTAL CAPABILITIES, OR LACK OF EXPERIENCE AND KNOWLEDGE OF THE PRODUCT AND SAFETY GUIDELINES. ALL USERS SHOULD HAVE TRAINED SUPERVISION OR INSTRUCTIONS CONCERNING THE USE OF THE APPLIANCE BY A PERSON RESPONSIBLE FOR HIS OR HER SAFETY.

SAFETY RULES

Please read the entire KRYTAC manual before operating the airsoft gun. This manual covers important safety, operational, and maintenance topics. It is important that the user reads and understands the manual in order to safely handle and operate the airsoft gun. Failure to follow the safety guidelines and/or operational instructions in this manual may result in serious personal injury or damage to the airsoft gun.

Safety Guidelines

EYE PROTECTION

Always wear eye protection while shooting, operating, and maintaining your airsoft guns.

EAR PROTECTION

With noise levels exceeding 85dB(A), appropriate ear protection must be used to prevent any damage due to sound emissions.

FIREARM SAFETY RULES

Always assume that the airsoft gun is loaded. Never assume the chamber is empty based on memory or from someone else's word. An airsoft gun can still fire with the magazine removed.

KEEP YOUR FINGER OFF THE TRIGGER

Remove your finger from the inside of the trigger guard until your sights are aligned on target and you are ready to fire.

MUZZLE CONTROL

Always keep the muzzle of the airsoft gun pointed in a safe direction. Never point the airsoft gun towards anything you do not intend to shoot.

KNOW YOUR TARGET AND ITS SURROUNDINGS (SAFETY DISTANCE)

Take note of objects in front of and beyond your target. Airsoft guns can shoot up to and beyond 150 feet/45.5 meters and may travel further than intended without an adequate backstop. Never shoot an airsoft gun directly at targets such as rocks, glass, water, or other hard surfaces that may ricochet BBs in unpredictable directions.



WARNING

SAFETY IS YOUR RESPONSIBILITY

The KRYTAC airsoft gun is designed and manufactured to KRYTAC's high standards. It was carefully inspected before it was packaged and shipped from our factory. It is the sole responsibility of the user for its safe use and handling. This airsoft gun is safe unless handled irresponsibly or misused.

BEWARE OF BARREL OBSTRUCTIONS

Ensure that the barrel of your airsoft gun is free and clear of any obstructions prior to firing the airsoft gun. Failure to do so may cause a malfunction, and in some cases damage the airsoft gun.

KEEP THE SAFETY ON

Keep the fire selector set to safe until your sights are aligned on target and you are ready to fire.

SAFETY RULES

FAILURE TO FIRE

If the airsoft gun fails to fire, misfires, or malfunctions, do not look into/down the barrel of the airsoft gun. BBs can jam in the chamber and can launch suddenly while under pressure causing serious injury.

FUSE

DO NOT REMOVE OR BYPASS THE FUSE. It is an integral part of the system. Alterations to the fuse will void warranty and may result in operational failure and critical damage to internal components.

MAINTAIN YOUR AIRSOFT GUN PROPERLY

Maintaining your airsoft gun as outlined in the manual ensures that your airsoft gun will be safe to shoot and perform to its designed specifications. Alterations, modifications, or adjustments may damage your airsoft gun, making it unsafe to shoot and/or voiding all warranty claims.

STORAGE AND TRANSPORT

Keep the fire selector on the airsoft gun set to safe, with the magazine and battery removed when storing your airsoft gun. Always store your airsoft gun in a safe place and out of the reach of children. When transporting your airsoft gun make sure that it is in a designated airsoft gun case. Never brandish your airsoft gun in public.



WARNING

IT IS YOUR RESPONSIBILITY TO SAFELY STORE AND TRANSPORT YOUR AIRSOFT GUN.

ORANGE TIP

Any alteration of the coloration or markings required by state and/or federal law may be deemed illegal in a court of law. All risks and responsibility of any alteration to the product will be assumed by the operators, owners and/or user of the product.



WARNING

THE ORANGE TIP DOES NOT DISTINGUISH YOUR AIRSOFT GUN AS A TOY, ALWAYS TREAT YOUR AIRSOFT GUN AS IF IT IS A REAL FIREARM.

HAZARDS OF BEING MISTAKEN FOR A REAL FIREARM

Due to the nature and design of some airsoft guns, they may be mistaken as a real firearm. It is strongly advised to operate an airsoft gun in the safety and privacy of your own home, or at a legally sanctioned location or game field. Police, Peace Officers, and Law Enforcement Officers are trained to treat objects that resemble a firearm as one. In the event that you are approached by a Law Enforcement Official, completely comply with their instructions. Never point an airsoft gun at a Law Enforcement Official. Confrontation with a Law Enforcement Official may result in serious injury or death.

ALCOHOL, MEDICATIONS AND DRUGS

Do not handle or operate your airsoft gun while under the influence of alcohol, medication, or drugs that may impair judgment.

SPECIFICATIONS



Caliber	6 mm
Overall Length	685 mm (27") - 768 mm (30.25")
Overall Height	180 mm (7.1")
Weight	2.75 kg (6.06 lbs)
Inner Barrel Length	155 mm
Inner Barrel Diameter	6.05 mm
Rate of Fire	24+ RPS

PERFORMANCE DETAILS ARE BASED ON U.S. SPECIFICATIONS AND CAN BE MODIFIED TO MEET THE LAWS AND REGULATIONS OF YOUR LOCAL REGION.

PRODUCT FEATURES

KRISS Vector GEN 2.1 upper receiver

KRISS adjustable DS150 stock

KRISS Vector MK5 modular handguard

CNC Picatinny hand stop

KRISS low profile flip-up front and rear sight

Extended battery cover

Ambidextrous fire selector

Semi, two-round burst, and full auto fire modes

Ambidextrous safety

KRISS Vector GEN2 pivoting trigger

MIL-STD 1913 picatinny bottom rail

T-Plug with Tamiya adaptor

MIL-STD 1913 picatinny top rail

Vector mechbox with 8mm Japanese bearing

Integrated FET system

Electronic trigger system

Quick change spring guide

Padded cylinder head

Relief-cut cylinder window

Adjustable rotary hop-up

Temperature and wear resistant hop-up bucking

30K high-torque, short type motor

VELOCITY AND ENERGY OUTPUT CHART

Your KRYTAC product has been configured to comply with your region's energy output regulations. The table below is a reference to the energy output specifications organized by region.

Country	Max Velocity	Energy Output
Japan, Italy	85 m/s	0.73 Joules
UK	110 m/s	1.24 Joules
Argentina, Austria, Belgium, Bosnia, Brazil, Bulgaria, Canada, Chile, Croatia, Cyprus, Czech Republic, Denmark, Estonia, Finland, France, Germany, Greece, Guatemala, Herzegovina, Hong Kong, Hungary, Iceland, Israel, Latvia, Liechtenstein, Lithuania, Macedonia, Moldavia, Netherlands, New Zealand, Norway, Paraguay, Philippines, Poland, Portugal, Romania, Russia, Serbia, Slovakia, Slovenia, South Africa, South Korea, Spain, Sweden, Switzerland, Turkey, U.S.A.	120 m/s	1.45 Joules

PACKAGE CONTENTS

- [1] KRIS Vector SMG Alpine Limited Edition
- [1] Magazine (short)
- [1] Magazine (long)
- [1] Set of front and rear sights
- [1] User's manual
- [1] Cleaning rod

LOADING THE MAGAZINE

1. Using a speed loader **(A)** or other magazine loader, insert the nozzle into the opening of the magazine **(B)**.
2. Press down on the loader plunger **(C)** to load BBs into the magazine. Stop once the magazine is full.



WARNING

DO NOT OVER
LOAD THE
MAGAZINE

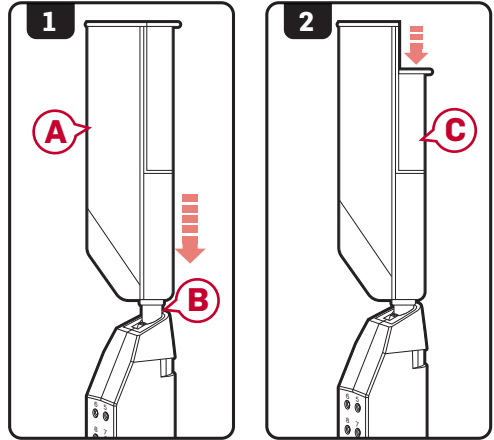

LOADING THE AIRSOFT GUN

1. Place the magazine **(A)** into the magazine well **(B)**. Tap the magazine to ensure that it is securely in position and seated properly.

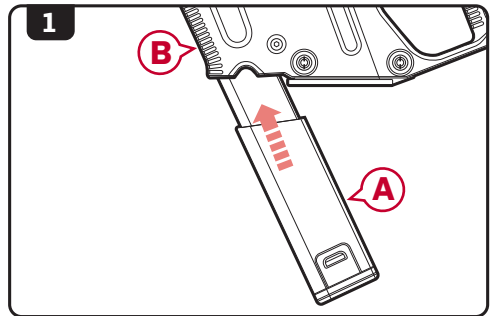

SAFETY SELECTOR SWITCH

SAFETY ENGAGED

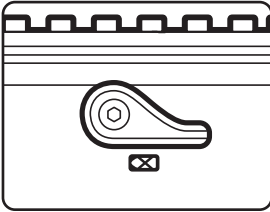

When in safe mode, airsoft gun will not fire.

SAFETY DISENGAGED

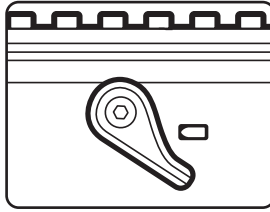

The airsoft gun will fire in accordance to the fire selector setting.

SAFETY TIP

It is advised when you are not ready to fire, keep the fire selector switch on the airsoft gun in the safe position.

FIRE SELECT

SEMI-AUTO

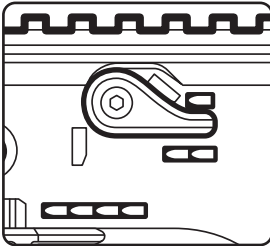

The airsoft gun will fire one shot for each time the trigger is engaged.

TWO-ROUND BURST

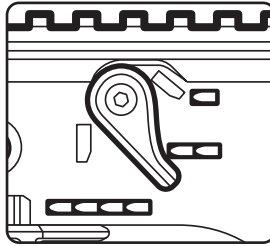

The firearm will fire two rounds for each pull of the trigger.

FULL-AUTO

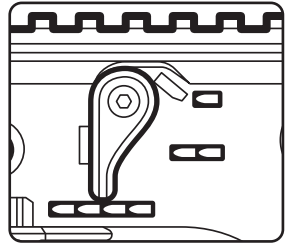

The firearm will continually fire while the trigger is engaged.



WARNING

DO NOT ENGAGE THE TRIGGER WHILE SWITCHING BETWEEN MODES ON THE FIRE SELECTOR.

DS150 STOCK

1. Press the stock adjustment latch **A** to slide the stock into the desired position.

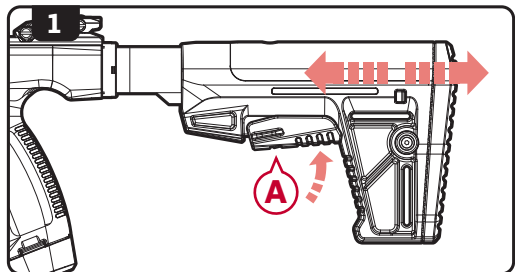

BATTERY INSTALLATION

1. Push the extended grip cover release tab **(A)** and pull out the grip cover **(B)** from the pistol grip **(C)** to show the male T-plug **(D)** .
2. Insert a battery with female T-plug **(E)** into the pistol grip and connect it to the male T-plug **(D)** .
3. Replace the extended grip cover.



WARNING

EXCESSIVE PULLING OR TUGGING OF THE BATTERY WIRES WHEN INSERTING OR REMOVING THE BATTERY CAN CAUSE DAMAGE TO THE WIRE ASSEMBLY AND CONNECTION TO THE TRIGGER HOUSING ASSEMBLY.

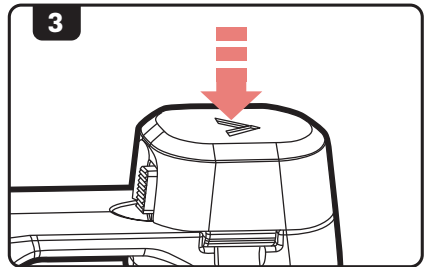
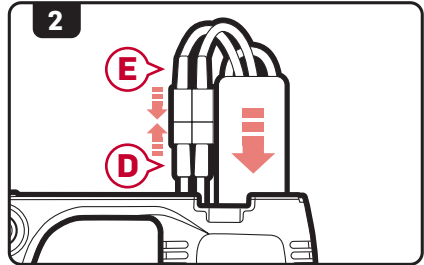
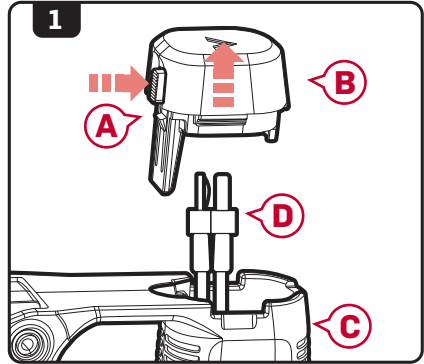

HOP-UP SYSTEM

The advanced KRYTAC rotary hop-up unit is a standard feature in all KRYTAC AEGs. Proper adjustment of the hop-up will allow the AEGs to fire in a variety of shooting environments to obtain optimal BB trajectory.

Hop-Up Adjustment

1. Pull the charging handle (A) 90° outward (B) then rearward (C), or manually flip open the dust cover (D). This will provide access to the hop-up adjustment dial (E).

2. Turn the dial up or down, an audible click will confirm each adjustment.

Increasing the number on the dial will increase the amount of hop-up on the BB. Decreasing the number will lower the amount of hop-up on the BB.

3. Once the hop-up has been set, flip the dust cover back down to its fully seated position.

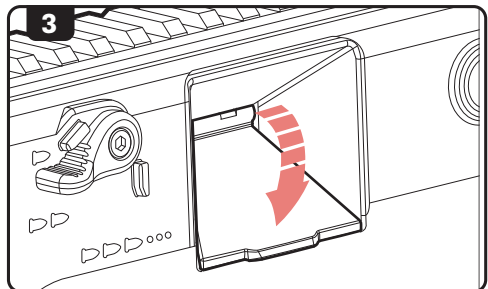
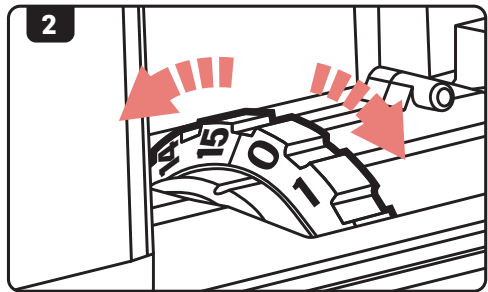
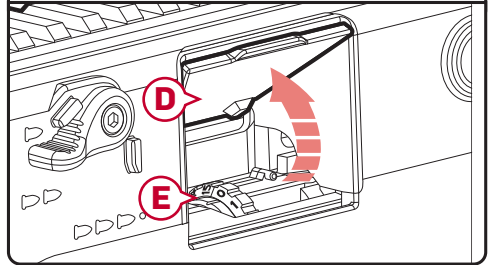
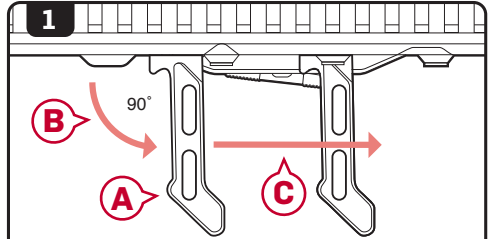

HOP-UP SYSTEM

Excessive Hop-Up

Airsoft BB travels in an extreme upward trajectory. Decrease the hop-up.

Ideal Hop-Up

Airsoft BB travels in a long, horizontal flight path.

Insufficient Hop-Up

Airsoft BB travels a short distance in a downward trajectory. Increase the hop-up.

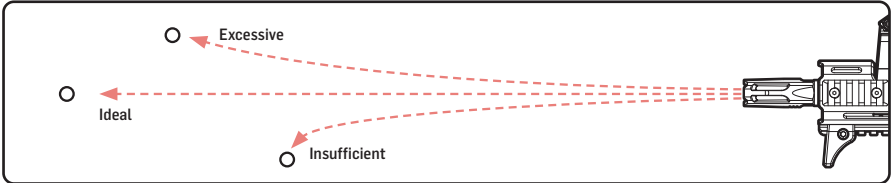

CLEARING JAMMED BBS

1. Disassemble the airsoft gun. (see pg.11 for disassembly instruction).
2. Turn the hop-up dial to "0" **(A)**.
3. Take the cleaning rod **(B)** and insert the unjamming side from the front of the barrel to clear out the jammed BB **(C)**.
4. Look through the barrel to ensure that it is cleared.
5. Reassemble the airsoft gun. (see pg.12 for assembly instruction).

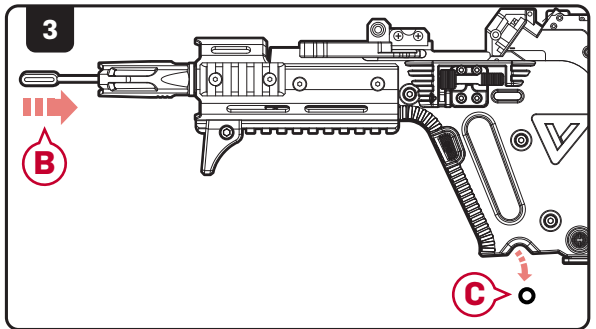
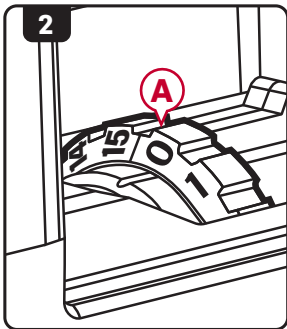

NOTE

Use only new, quality airsoft BBs. Never use recycled or low quality airsoft BBs, doing so may cause excessive jamming. In most cases, it can severely damage the internal gearbox and/or hop-up and inner barrel.

DISASSEMBLY

NOTE

Before opening up the receiver, remove the magazine and fire the airsoft gun in a safe direction to ensure that the hop-up chamber is clear of any BBs.

1. Set the AEG to safe mode.
2. Remove the extended grip cover (A) and disconnect (B) the battery.
3. Remove the 3 body pins (C) as shown. Take care not to lose the pins.
4. Pull the upper and lower receiver away from each other.



WARNING

MISSING BODY PINS CAN
RESULT IN A DAMAGED OR
BROKEN PISTON.

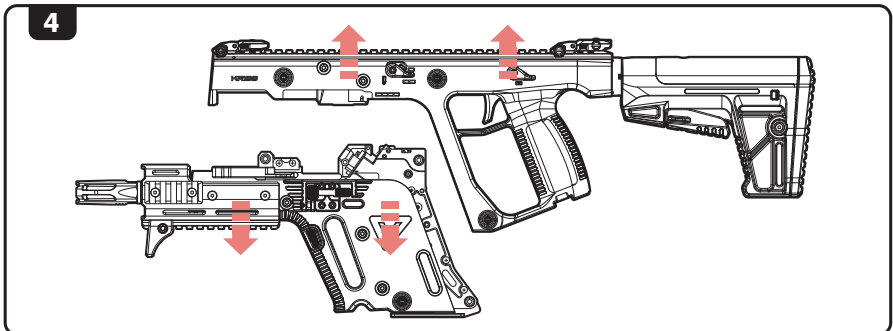
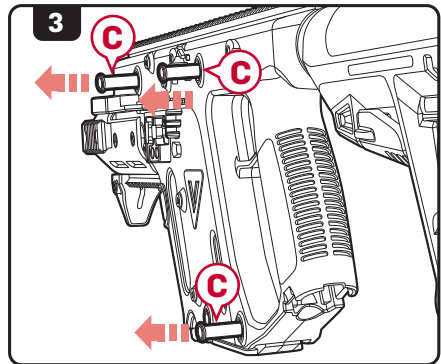
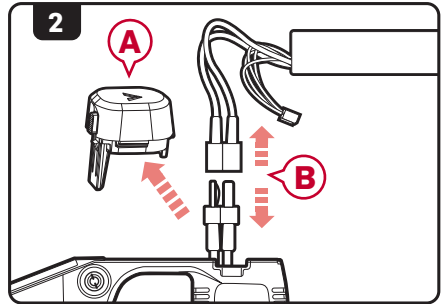
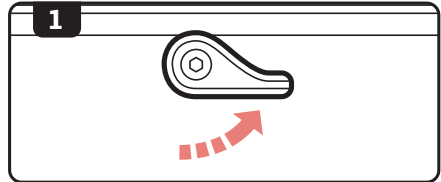

ASSEMBLY

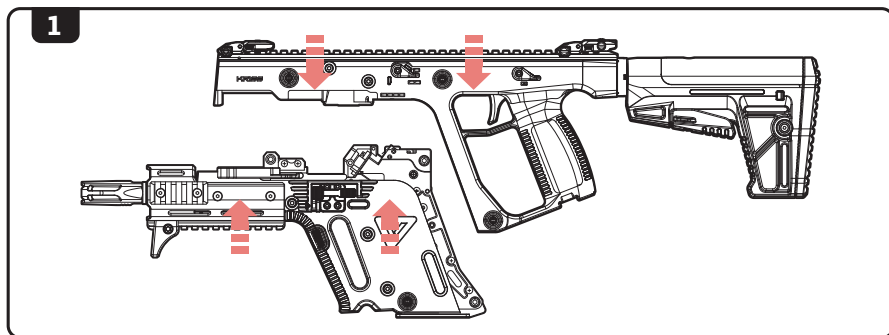

1. Slide the upper receiver back onto the lower receiver.
2. Reinstall the 3 body pins.
3. Connect and place battery into grip and replace the grip cover.

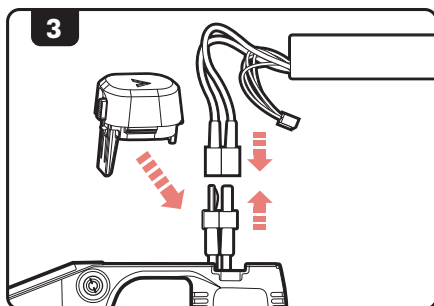
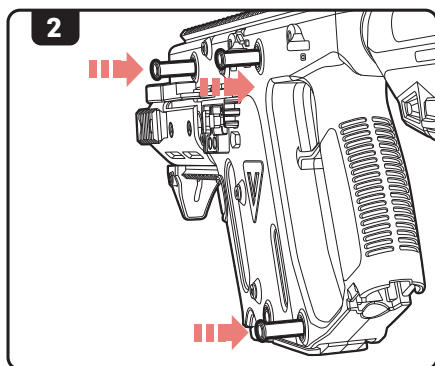

MAIN SPRING ACCESS

1. Remove the rear lower break down pin **(A)**.
2. Remove the set screw **(B)** from the front lower break down pin with a Phillips #2 screw driver.
3. Hold the spring plate assembly **(C)** firmly in place and remove the front lower break down pin **(D)**.
4. Remove the spring plate assembly **(C)** with the spring guide **(E)** and the main spring **(F)**.

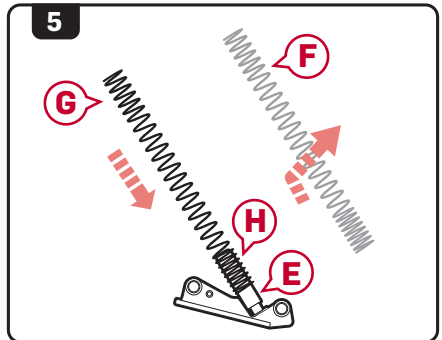
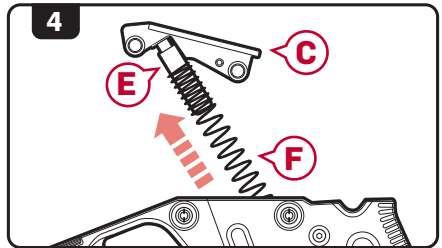
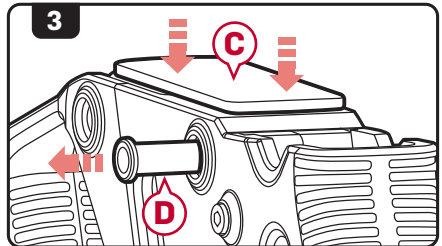
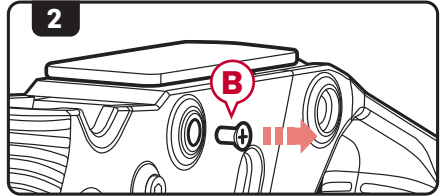
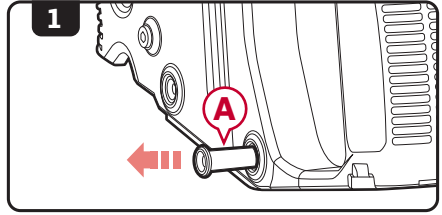

THE SPRING PLATE ASSEMBLY HOLDS THE SPRING GUIDE **(E)** AND THE MAIN SPRING **(F)** IN PLACE WHICH IS UNDER EXTREME PRESSURE. REMOVE WITH CAUTION.

CAUTION

TAKE NOTE OF THE ORIENTATION OF THE SPRING. THE MORE TIGHTLY COILED END **(H)** GOES ONTO THE SPRING GUIDE **(E)**.

5. Replace existing main spring **(F)** with the desired main spring **(G)**.
6. Re-insert the main spring and the spring plate assembly.
7. Reinstall and secure the lower break down pins.

CLEANING

NOTE

WHILE POINTING THE AIRSOFT GUN IN A SAFE DIRECTION, REMOVE THE MAGAZINE AND CYCLE THE GEARBOX UNTIL NO BBS EXIT THE INNER BARREL. PLACE THE AIRSOFT GUN IN SAFE MODE AND DISCONNECT THE BATTERY PRIOR TO ANY CLEANING PROCEDURES.

1. Wipe down the external parts of the gun and remove any dirt and debris.

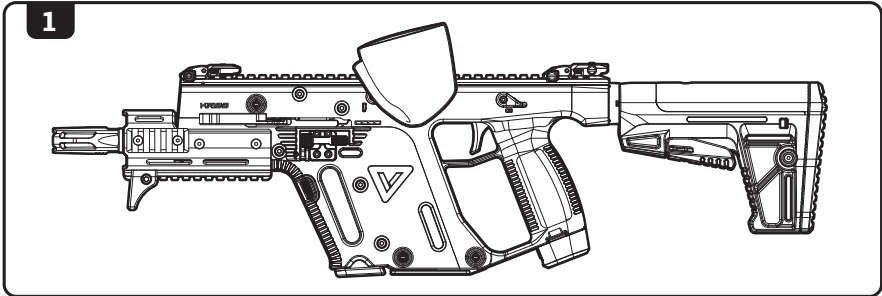

DO NOT ADD OIL TO THE HOP-UP BUCKING. EXCESSIVE OIL ON THE HOP-UP BUCKING MAY NEGATE THE HOP-UP, DECREASING RANGE AND ACCURACY.

OPERATING UNDER HARSH CONDITIONS

When operating under harsh conditions, special maintenance may be required to match the climate conditions of a specific operational area.

Dust and Sand

In harsh dusty or sandy environments, excessive debris can cause malfunctions and/or excessive wear on parts. Keep the gun covered and protected while not in use. When performing maintenance, use lubrication sparingly as it tends to attract dirt and other particles. After use in a dusty or sandy area, always field strip the gun, as outlined in the Disassembly section, cleaning all the areas that can be reached with a soft, clean, lint-free cloth.

Heavy Rain

Never submerge or expose your gun to extremely wet environments. Exposure to such conditions may cause electrical failure and fluid to build-up inside the gearbox. Dry completely with a clean, lint-free cloth and clean inner barrel when necessary.

HEARING PROTECTION REQUIREMENT

HEARING PROTECTION REQUIREMENT FOR EUROPEAN COMMUNITY

The KRYTAC KRISSE® VECTOR SMG ALPINE LIMITED EDITION fulfills all relevant provisions of:

EMC Directive (2014/30/EU)
RoHS Directive (2011/65/EU)
General Product Safety Directive (2001/95/EC)

In conjunction with the following harmonized standards or technical specifications for the design and manufacture

EN 50581:2012; EN 55014-1:2006; EN 55014-2:1997

In accordance with the above mentioned standards, in some applications, noise or vibration levels may exceed the minimum Noise levels of 85db(A). If Noise levels exceed 85dB(A), appropriate ear protection must be used to prevent any damages due to sound emissions.

CONTACT INFORMATION

For additional troubleshooting, information, or questions regarding KRYTAC customer service:

Submit a contact form at: www.krytac.com

Email us at: support@krytac.com

Join the KRYTAC Community and visit <http://forums.krytac.com> for any additional technical questions and information about your KRYTAC.

TROUBLE SHOOTING GUIDE



WARNING

WHEN TROUBLESHOOTING, FOLLOW THE SAFETY MEASURES DESCRIBED IN THIS MANUAL.

SYMPTOMS	CAUSE	SOLUTIONS
Not firing/No sound	Safety is engaged	Change selector to Semi Auto or Full Automatic Mode
	Low power or dead battery	Charge and replace battery
	Blown out fuse	Replace with new fuse
	Loose connection	Contact customer service for professional care
Motor is running but gun is not firing	Inspect magazine	Check if magazine is properly loaded into the gun Ensure magazine is loaded with ammunition Ensure the hi-cap magazine is properly wound
Motor or battery is hot after short use	Damaged battery	Inspect and/or replace battery
	Loose connection terminal	Contact customer service for professional care
Semi-Auto feature not functioning properly	Battery voltage or discharge is too high	Condition or replace battery
Semi-Auto feature not working at all	Disconnecter is not engaged properly	Reset the disconnecter by setting the selector to safe, then to automatic, then to semi
Firing cycle slowing down	Battery is low on power	Charge or replace battery
High pitch or grinding noise	Motor level is not adjusted properly	Contact customer service for professional care
BB travels upward	Hop-up adjusted too high	Dial down the hop-up adjustment
BB travels downward	Hop-up adjusted too low	Dial up the hop-up adjustment
BB double feeding or rolling out of the barrel	Excessive grease or oil in the hopup chamber	Fire at least 200 rounds to eliminate excessive grease from the chamber Clean hop-up unit with supplied cleaning rod
	Hop-up unit is turned off	Turn hop-up unit on
Hop-up can't be adjusted	Hop-up adjustment arm is not set properly	Reset hop-up adjustment arm
Inner barrel is jammed or jamming	Use of recycled or low quality BBs	Use only KRYTAC branded or other high quality BBs
	Inner Barrel is contaminated with BBs or debris	Clear and/or clean inner barrel with supplied cleaning rod (See page 10 for clearing jam section.)
Mmagazine not feeding	BBs are lodged inside the magazine	Shake or tap magazine to clear the jam
	Internal obstruction	Contact customer service for professional care

COMPONENT DIAGRAM

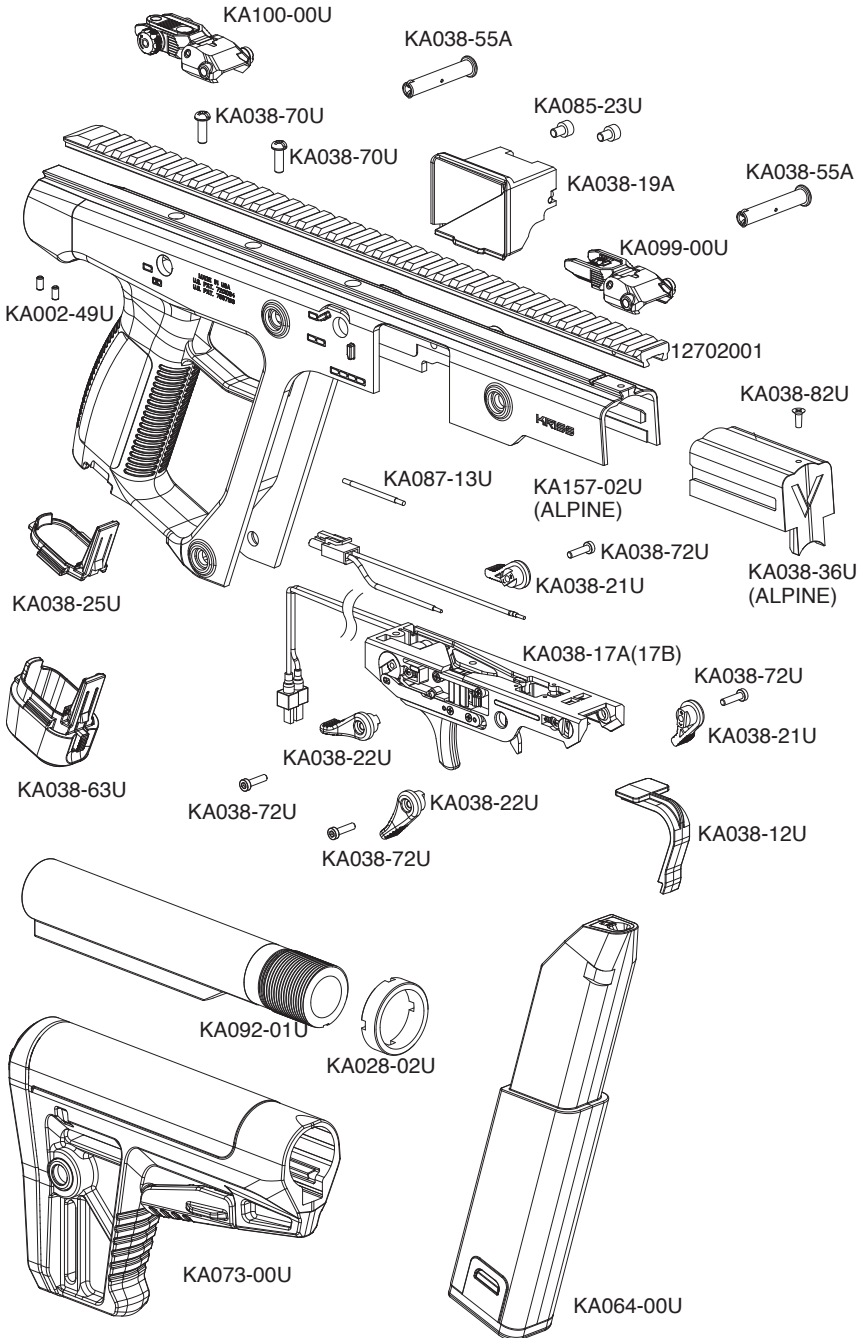

COMPONENT DIAGRAM

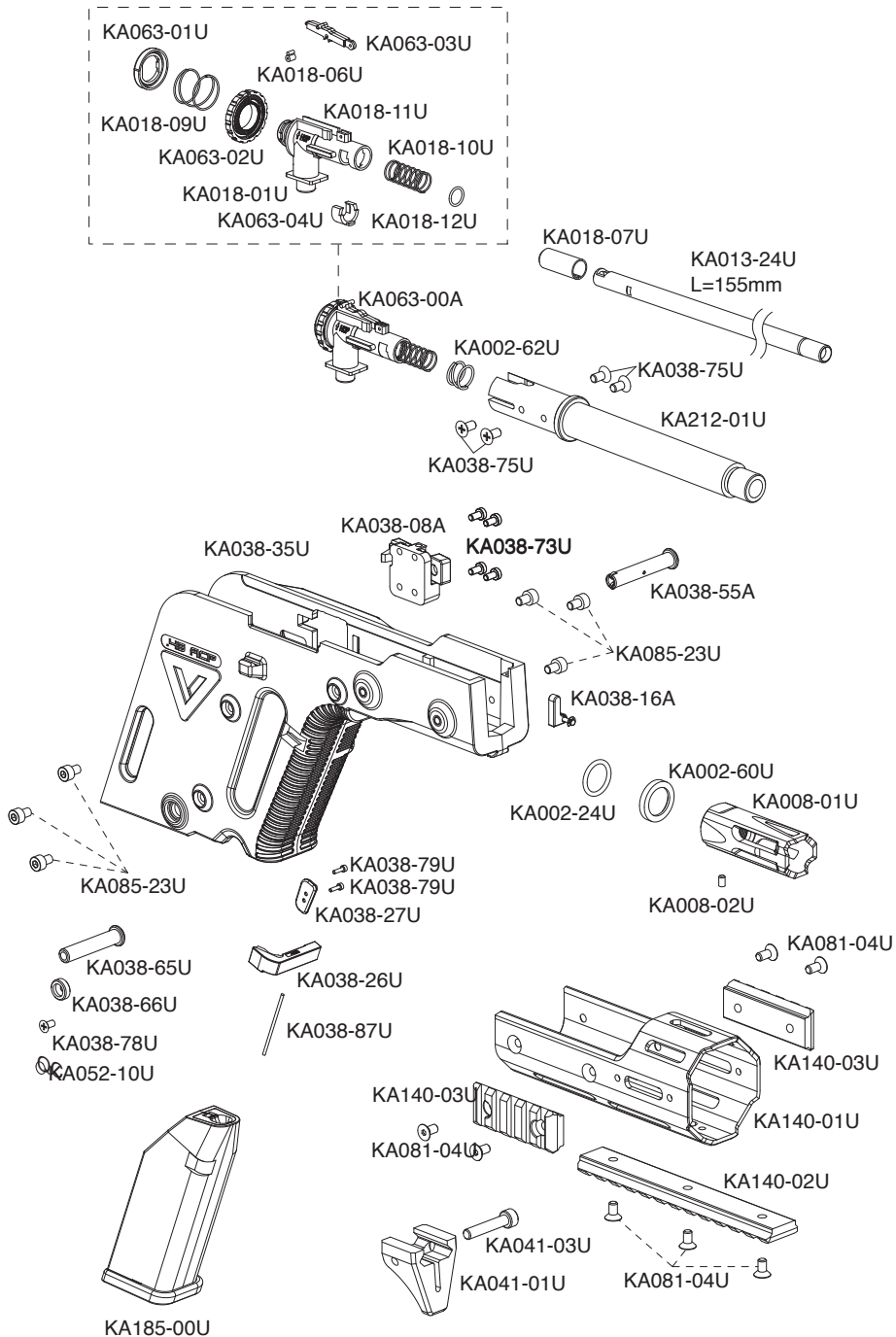

COMPONENT DIAGRAM

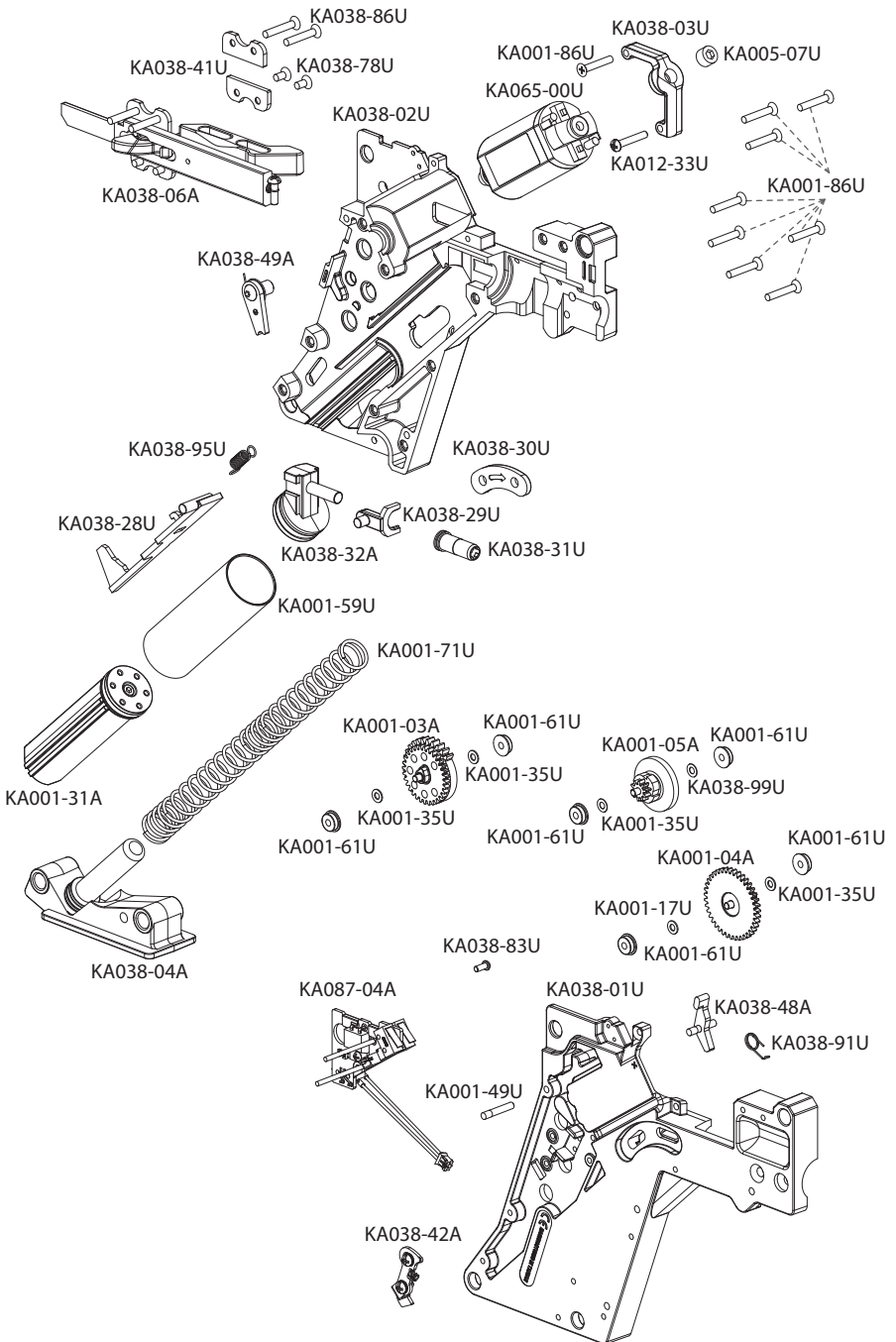

COMPONENT LIST

PART #	NAME
KA001-03A	SECTOR GEAR
KA001-04A	SPUR GEAR
KA001-05A	BEVEL GEAR
KA001-17U	PISTON HEAD SHIM
KA001-31A	PISTON ASSEMBLY
KA001-35U	SHIM
KA001-49U	ANTI-REVERSE LATCH PIN
KA001-59U	CYLINDER (TYPE 1)
KA001-61U	STEEL BUSHING
KA001-71U	MAIN SPRING (M120)
KA001-86U	GEARBOX SHELL SCREW (LONG)(11)
KA002-24U	CRUSH WASHER O-RING
KA002-49U	LOCKING SCREW
KA002-60U	CRUSH WASHER
KA002-62U	HOP-UP OUTER TENSION SPRING
KA005-07U	RETENSION SCREW
KA005-08U	SIDE RAIL SCREW
KA008-01U- OP	FLASH HIDER (ORANGE PLASTIC)
KA008-02U	SET SCREW
KA012-33U	RECEIVER PANEL TOP SCREW
KA013-24U	INNER BARREL (155MM)
KA018-01U	HOP CHAMBER
KA018-06U	NUB
KA018-07U	BUCKING
KA018-09U	ADJUSTMENT SPRING
KA018-10U	HOP UP TENSION SPRING
KA018-11U	ADJUSTMENT LEVER PIN
KA018-12U	FRONT BARREL O-RING
KA028-02U	CASTLE NUT
KA038-01U	GEARBOX PANEL (RIGHT)
KA038-02U	GEARBOX PANEL (LEFT)
KA038-03U	MOTOR BRACKET
KA038-04A	SPRING PLATE
KA038-06A	CHARGING HANDLE ASSEMBLY
KA038-08A	BOLT CATCH BLOCK ASSEMBLY
KA038-12U	TRIGGER COVER
KA038-16A	BOLT LOCK TRIGGER ASSEMBLY
KA038-17A	TRIGGER HOUSING ASSEMBLY (TAMIYA)
KA038-17B	TRIGGER HOUSING ASSEMBLY (T-PLUG)
KA038-19A	EJECTION PORT ASSEMBLY
KA038-21U	SAFETY/SELECTOR LEVER (LEFT)
KA038-22U	SAFETY/SELECTOR LEVER (RIGHT)
KA038-25U	GRIP COVER
KA038-26U	MAGAZINE RELEASE BUTTON
KA038-27U	MAGAZINE RELEASE
KA038-28U	TAPPET PLATE
KA038-29U	TAPPET PLATE ARM
KA038-30U	TAPPET PLATE LINK
KA038-31U	NOZZLE
KA038-32A	CYLINDER HEAD BASE
KA038-35U	LOWER RECIEVER HOUSING
KA038-36U	NOSE CAP (ALPINE)
KA038-41U	CHARGING HANDLE COVER (2)
KA038-42A	DISCONNECTOR ASSEMBLY
KA038-48A	ANTI-REVERSE LATCH (ARL) ASSEMBLY
KA038-49A	ANTI-SECTOR GEAR REVERSE LEVER (ASGRL) ASSEMBLY
KA038-55A	BREAK DOWN PIN ASSEMBLY
KA038-63U	EXTENDED GRIP COVER
KA038-65U	SECURITY PIN
KA038-66U	SECURITY WASHER
KA038-70U	TRIGGER GROUP HOUSING SCREWS

COMPONENT LIST

KA038-72U	SELECTOR SCREWS (4)
KA038-73U	BOLT LOCK BLOCK SCREWS (4)
KA038-75U	BARREL MOUNTING SCREW
KA038-78U	CHARGING HANDLE COVER SCREW (3)
KA038-79U	MAGAZINE RELEASE SCREW (2)
KA038-82U	NOSE CAP SCREW
KA038-83U	SELECTOR BOARD SCREW
KA038-86U	CHARGING SLIDER SPRING
KA038-91U	ANTI-REVERSE LATCH SPRING (ARL SPRING)
KA038-95U	TAPPET PLATE SPRING
KA041-01U	VECTOR HAND STOP
KA041-03U	VECTOR HAND STOP PIN
KA063-00A	HOP-UP ASSEMBLY
KA063-01U	HOPUP DIAL RETAINER
KA063-02U	HOPUP DIAL
KA063-03U	HOPUP ARM
KA063-04U	BARREL CLIP
KA064-00U	VECTOR MAGAZINE (LONG)
KA065-00U	MOTOR
KA073-00U	KRISS® DS150 STOCK
KA081-04U	M-LOK HAND GUARD SCREW
KA085-23U	BODY SCREW
KA087-04A	SELECTOR BOARD ASSEMBLY
KA087-13U	SAFETY PLATE RETAINER
KA092-01U	BUFFER TUBE
KA099-00U	FRONT SIGHT
KA100-00U	REAR SIGHT
K140-01U	KRISS VECTOR MK5 MODULAR HAND GUARD
K140-02U	BOTTOM RAIL (LONG)
K140-03U	SIDE RAIL (SHORT)
KA157-02U	UPPER RECEIVER HOUSING (ALPINE)
KA185-00U	MAGAZINE (SHORT)

KA212-01U	OUTER BARREL
12702001	TOP RAIL

www.krytac.com

© Copyright 2019
KRISS INDUSTRIES ASIA
Subject to change

V.03 R.2020.10.05

