



KRYTAC®

OWNER'S MANUAL

TRIDENT

MK II

PDW

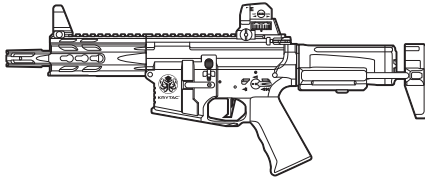

TABLE OF CONTENTS

Safety Rules	2
Specifications	4
Velocity and Energy Output Chart	5
Package Contents	5
Loading the Magazine	6
Fire Selector Switch.....	7
Retractable Stock	7
Battery Installation	8
Hop-Up System	9
Clearing Jammed BBs.....	10
Disassembly	11
Assembly	12
Main Spring Access	13
Cleaning and Maintenance.....	16
Operating Under Harsh Conditions	18
Trouble Shooting Guide.....	19
Hearing Protection Requirement	20
Contact Information	20
Component Diagrams and Lists	21



WARNING

THIS PRODUCT IS NOT INTENDED FOR USE BY UNTRAINED PERSONS (INCLUDING CHILDREN) WITH OR WITHOUT PHYSICAL OR MENTAL HANDICAPS. THESE HANDICAPS INCLUDE REDUCED PHYSICAL, SENSORY OR MENTAL CAPABILITIES, OR LACK OF EXPERIENCE AND KNOWLEDGE OF THE PRODUCT AND SAFETY GUIDELINES. ALL USERS SHOULD HAVE TRAINED SUPERVISION OR INSTRUCTIONS CONCERNING THE USE OF THE APPLIANCE BY A PERSON RESPONSIBLE FOR HIS OR HER SAFETY.

SAFETY RULES

Please read the entire KRYTAC manual before operating the airsoft gun. This manual covers important safety, operational, and maintenance topics. It is important that the user reads and understands the manual in order to safely handle and operate the airsoft gun. Failure to follow the safety guidelines and/or operational instructions in this manual may result in serious personal injury or damage to the airsoft gun.

Safety Guidelines

EYE PROTECTION

Always wear eye protection while shooting, operating, and maintaining your airsoft guns.

EAR PROTECTION

With noise levels exceeding 85dB(A), appropriate ear protection must be used to prevent any damage due to sound emissions.

FIREARM SAFETY RULES

Always assume that the airsoft gun is loaded. Never assume the chamber is empty based on memory or from someone else's word. An airsoft gun can still fire with the magazine removed.

KEEP YOUR FINGER OFF THE TRIGGER

Remove your finger from the inside of the trigger guard until your sights are aligned on target and you are ready to fire.

MUZZLE CONTROL

Always keep the muzzle of the airsoft gun pointed in a safe direction. Never point the airsoft gun towards anything you do not intend to shoot.

KNOW YOUR TARGET AND ITS SURROUNDINGS (SAFETY DISTANCE)

Take note of objects in front of and beyond your target. Airsoft guns can shoot up to and beyond 150 feet/45.5 meters and may travel further than intended without an adequate backstop. Never shoot an airsoft gun directly at targets such as rocks, glass, water, or other hard surfaces that may ricochet BBs in unpredictable directions.



WARNING

SAFETY IS YOUR RESPONSIBILITY

The KRYTAC airsoft gun is designed and manufactured to KRYTAC's high standards. It was carefully inspected before it was packaged and shipped from our factory. It is the sole responsibility of the user for its safe use and handling. This airsoft gun is safe unless handled irresponsibly or misused.

BEWARE OF BARREL OBSTRUCTIONS

Ensure that the barrel of your airsoft gun is free and clear of any obstructions prior to firing the airsoft gun. Failure to do so may cause a malfunction, and in some cases damage the airsoft gun.

KEEP THE SAFETY ON

Keep the fire selector set to safe until your sights are aligned on target and you are ready to fire.

SAFETY RULES

FAILURE TO FIRE

If the airsoft gun fails to fire, misfires, or malfunctions, do not look into/down the barrel of the airsoft gun. BBs can jam in the chamber and can launch suddenly while under pressure causing serious injury.

FUSE

DO NOT REMOVE OR BYPASS THE FUSE. It is an integral part of the system. Alterations to the fuse will void warranty and may result in operational failure and critical damage to internal components.

MAINTAIN YOUR AIRSOFT GUN PROPERLY

Maintaining your airsoft gun as outlined in the manual ensures that your airsoft gun will be safe to shoot and perform to its designed specifications. Alterations, modifications, or adjustments may damage your airsoft gun, making it unsafe to shoot and/or voiding all warranty claims.

STORAGE AND TRANSPORT

Keep the fire selector on the airsoft gun set to safe, with the magazine and battery removed when storing your airsoft gun. Always store your airsoft gun in a safe place and out of the reach of children. When transporting your airsoft gun make sure that it is in a designated airsoft gun case. Never brandish your airsoft gun in public.



WARNING

IT IS YOUR RESPONSIBILITY TO SAFELY STORE AND TRANSPORT YOUR AIRSOFT GUN.

ORANGE TIP

Any alteration of the coloration or markings required by state and/or federal law may be deemed illegal in a court of law. All risks and responsibility of any alteration to the product will be assumed by the operators, owners and/or user of the product.



WARNING

THE ORANGE TIP DOES NOT DISTINGUISH YOUR AIRSOFT GUN AS A TOY, ALWAYS TREAT YOUR AIRSOFT GUN AS IF IT IS A REAL FIREARM.

HAZARDS OF BEING MISTAKEN FOR A REAL FIREARM

Due to the nature and design of some airsoft guns, they may be mistaken as a real firearm. It is strongly advised to operate an airsoft gun in the safety and privacy of your own home, or at a legally sanctioned location or game field. Police, Peace Officers, and Law Enforcement Officers are trained to treat objects that resemble a firearm as one. In the event that you are approached by a Law Enforcement Official, completely comply with their instructions. Never point an airsoft gun at a Law Enforcement Official. Confrontation with a Law Enforcement Official may result in serious injury or death.

ALCOHOL, MEDICATIONS AND DRUGS

Do not handle or operate your airsoft gun while under the influence of alcohol, medication, or drugs that may impair judgment.

SPECIFICATIONS



Caliber	6mm
Overall Length	527 mm (20.7") - 610 mm (24")
Overall Height	185 mm (7.3")
Weight	2.3 kg (5 lbs)
Outer Barrel Length	140 mm (5.5")
Inner Barrel Length	155 mm
Inner Barrel Diameter	6.05 mm
Rate of Fire	20+ RPs

PERFORMANCE DETAILS ARE BASED ON U.S. SPECIFICATIONS AND CAN BE MODIFIED TO MEET THE LAWS AND REGULATIONS OF YOUR LOCAL REGION.

PRODUCT FEATURES

KRYTAC MK II metal alloy receiver

TR105 keymod hand guard

KRIS pistol grip

Two-position compact carbine stock

Ambidextrous fire selector

Licensed CMC trigger

MIL-STD 1913 Picatinny top rail

Sling attachment loop

8mm ball bearing mechbox

Integrated FET system

Easy maintenance spring guide

Padded cylinder head

Relief-cut cylinder window

Anti-corrosion mechbox coating

Adjustable rotary hop-up

Temperature and wear resistant hop-up bucking

KRYTAC 30K high torque motor

VELOCITY AND ENERGY OUTPUT CHART

Your KRYTAC product has been configured to comply with your region's energy output regulations. The table below is a reference to the energy output specifications organized by region.

Country	Max Velocity	Energy Output
Japan, Italy	85 m/s	0.73 Joules
UK	110 m/s	1.24 Joules
Austria, Belgium, Bosnia, Brazil, Bulgaria, Canada, Chile, Croatia, Cyprus, Czech Republic, Denmark, Estonia, Finland, France, Germany, Greece, Guatemala, Herzegovina, Hong Kong, Hungary, Iceland, Israel, Latvia, Liechtenstein, Lithuania, Macedonia, Moldavia, Netherlands, New Zealand, Norway, Paraguay, Philippines, Poland, Portugal, Romania, Russia, Serbia, Slovakia, Slovenia, South Africa, South Korea, Spain, Sweden, Switzerland, Turkey, U.S.A.	120 m/s	1.45 Joules

PACKAGE CONTENTS

- [1] Trident MK II PDW airsoft gun
- [1] Magazine
- [1] 2.5 mm Allen wrench
- [1] User's manual
- [1] Cleaning rod

LOADING THE MAGAZINE

High-Cap

1. Place the hi-cap magazine with the trap door **(A)** facing upward. Open the trap door and dispense BBs into the BB well.
2. When full, close the trap door and turn the winding wheel **(B)** forward until the 'clicking' changes tone.

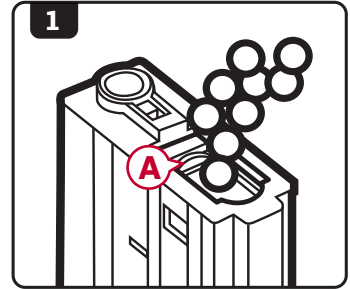

WARNING

**DO NOT OVER LOAD THE
MAGAZINE**

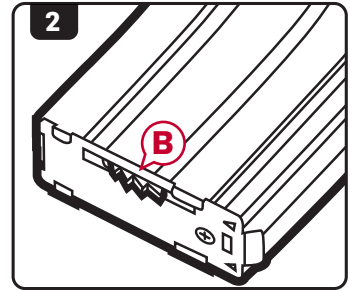

Mid-Cap

1. Using a speed loader or other magazine loader, insert the nozzle into the opening of the magazine.
2. Press down on the loader plunger to load BBs into the magazine.
3. Stop once the magazine is full, do not force more into the magazine.

FIRE SELECTOR SWITCH

SAFE MODE

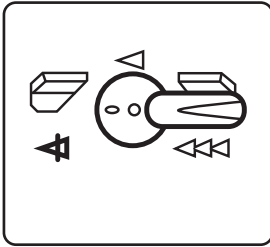

When in safe mode, the trigger will not engage and the airsoft gun will not fire.

SEMI-AUTO MODE

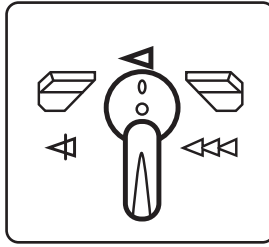

While in semi-auto mode, the airsoft gun will only fire one shot for each time the trigger is engaged.

FULL-AUTO MODE

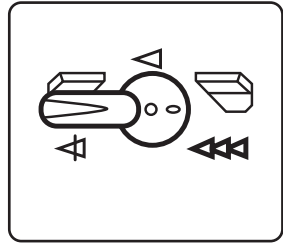

In full-auto mode, the gun will continuously fire as long as the trigger remains engaged.

SAFETY TIP

It is advised when you are not ready to fire, keep the fire selector switch on the airsoft gun in the safe position.



WARNING

DO NOT ENGAGE THE TRIGGER WHILE SWITCHING BETWEEN MODES ON THE FIRE SELECTOR.

RETRACTABLE STOCK

1. To extend, depress the stock release button **(A)** and pull the retractable stock **(B)** to its rear-most position.
2. To retract, depress the stock release button **(A)** and push the retractable stock **(B)** to its forward-most position.

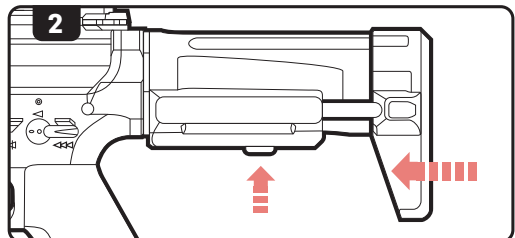
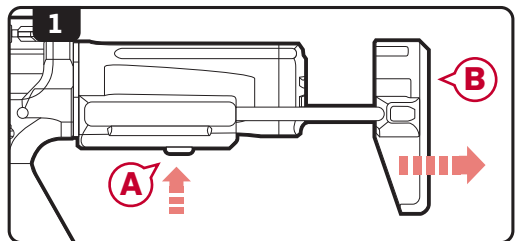

BATTERY INSTALLATION



WARNING

ENSURE THAT THE STOCK IS IN THE FULLY EXTENDED POSITION BEFORE OPENING THE STOCK COVER. DO NOT REMOVE THE STOCK COMPLETELY FROM THE GUN.

1. Extend the retractable stock **(A)** and remove the allen screw **(B)** from the stock cap **(C)** using a 2.5mm allen key **(D)**.
2. Remove the stock cap **(C)**.
3. Connect a small battery **(E)** to the connector.
4. Curl the connection wires against the side of the battery and insert together into the stock.
5. Replace the stock cap and secure with the allen screw using the 2.5mm allen key.

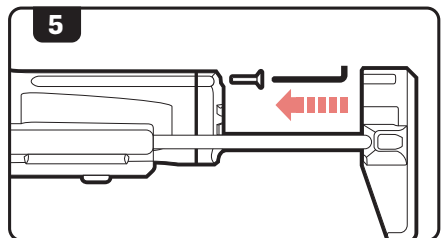
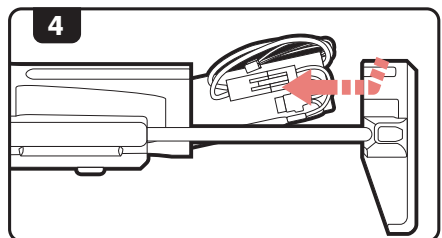
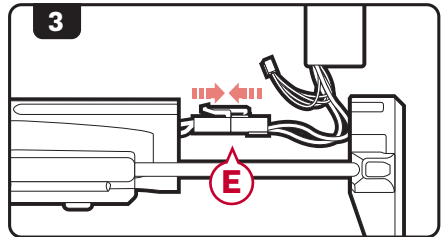
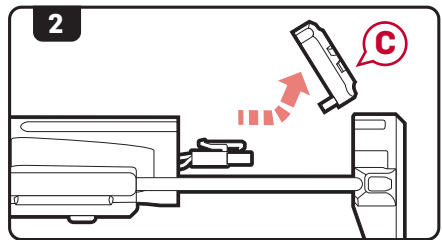
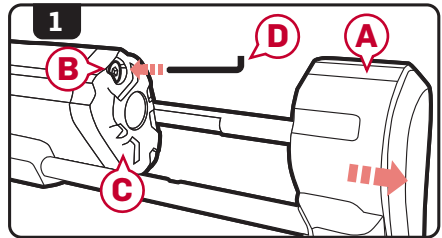

HOP-UP SYSTEM

The advanced KRYTAC rotary hop-up unit is a standard feature in the Trident series AEGs. Proper adjustment of the hop-up will allow the AEGs to fire in a variety of shooting environments to obtain optimal BB trajectory.

Hop-Up Adjustment

1. Pull the charging handle **(A)** rearward locking the bolt plate **(B)**. This will provide access to the hop-up adjustment dial **(C)**.

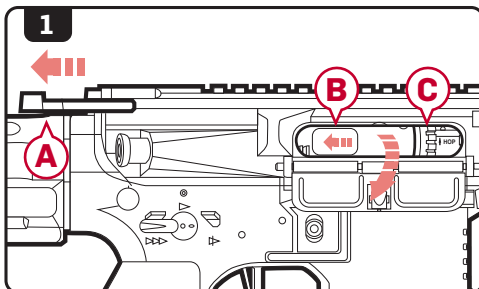

2. Turn the dial up or down, an audible click will confirm each adjustment.

Increasing the number on the dial will increase the amount of hop-up on the BB. Decreasing the number will lower the amount of hop-up on the BB.

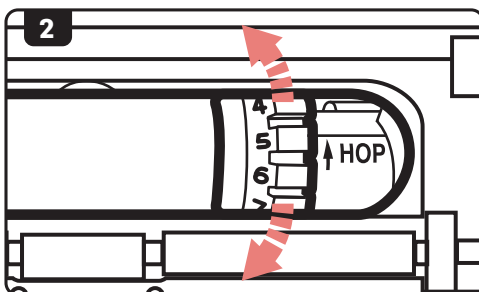

3. Once the hop-up has been set, depress the bolt catch release **(D)** to return the bolt plate back to its fully seated position.

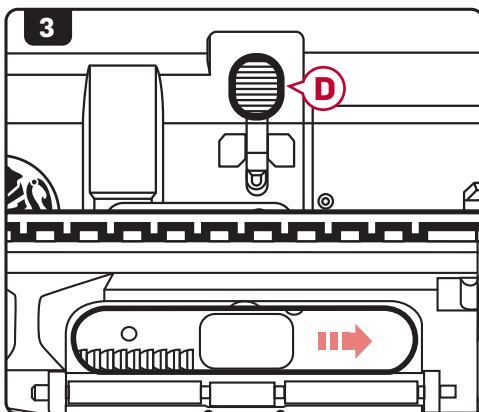

HOP-UP SYSTEM

Excessive Hop-Up

Airsoft BB travels in an extreme upward trajectory. Decrease the hop-up.

Ideal Hop-Up

Airsoft BB travels in a long, horizontal flight path.

Insufficient Hop-Up

Airsoft BB travels a short distance in a downward trajectory. Increase the hop-up.

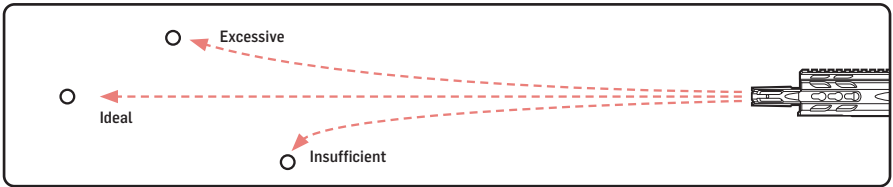

CLEARING JAMMED BBS

1. Disassemble the airsoft gun and remove the inner barrel assembly (A). (see pg.11 for disassembly instruction).
2. Lift the Hop-up lever (B) from the inner barrel assembly (refer to step 3 of pg.16).
3. Take the cleaning rod (C) and insert the unjamming side from the front of the barrel through to the rear to clear out the jammed BB.
4. Look through the barrel to ensure that it is cleared.
5. Reassemble the airsoft gun. (see pg.12 for assembly instruction).

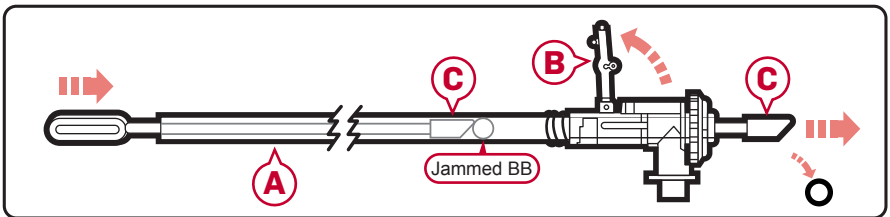

NOTE

Use only new, quality airsoft BBs. Never use recycled or low quality airsoft BBs, doing so may cause excessive jamming. In most cases, it can severely damage the internal gearbox and/or hop-up and inner barrel.

DISASSEMBLY

NOTE

Before opening up the receiver, remove the magazine and fire the airsoft gun in a safe direction to ensure that the hop-up chamber is clear of any BBs.

1. Set the AEG to safe mode.
2. Remove the stock cap (see pg.8 for instruction) then disconnect and remove the battery.
3. Pull the charging handle rearward to lock the bolt plate back.
4. Remove **ONLY** the front pin **(A)** from the receiver.
5. Slide the upper receiver forward and away from the lower receiver.

NOTE

The bolt catch lever **(B)** may fall off of the lower receiver when separating the receivers. Avoid turning or jostling the lower receiver to help prevent loss of the bolt catch lever.

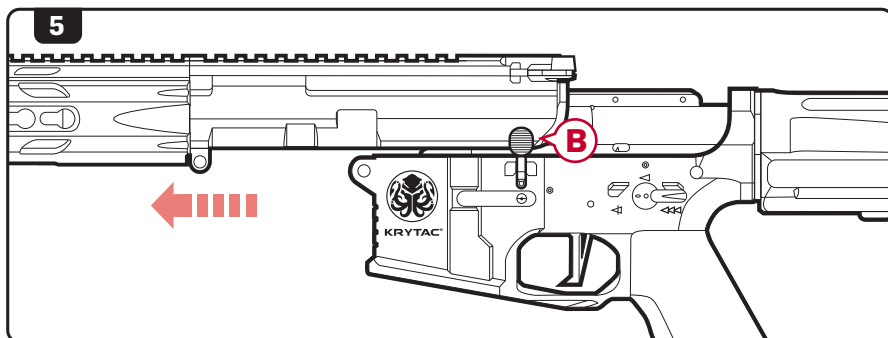
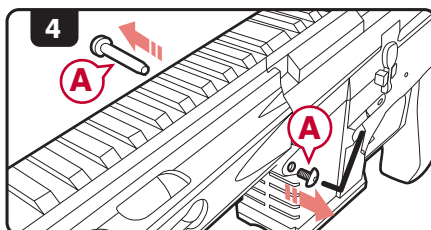
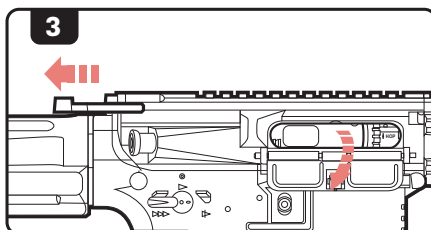
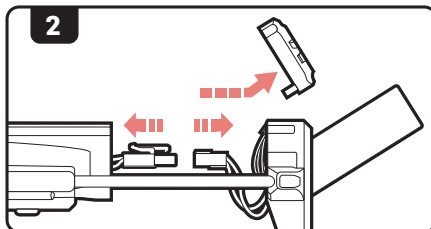
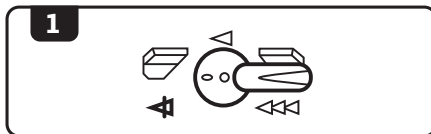

DISASSEMBLY

6. Slide the hop-up and inner barrel assembly **C** out of the upper receiver.

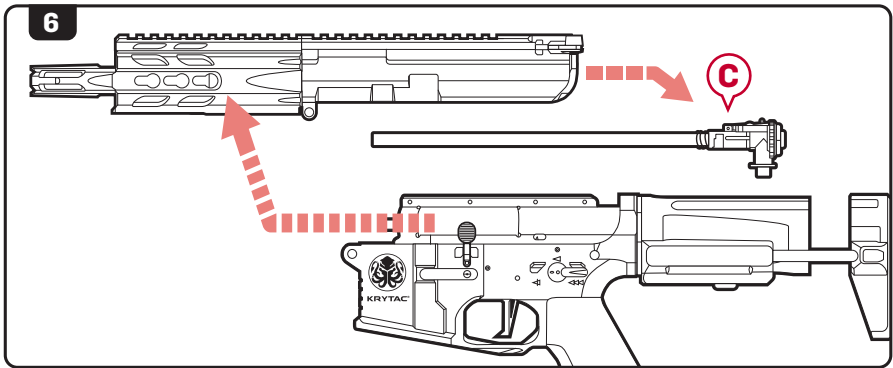

ASSEMBLY

1. Insert the hop-up and inner barrel assembly into the upper receiver.
2. Ensure that the bolt catch lever is in place, then slide the upper receiver back onto the lower receiver.
3. Reinstall and secure the front body pin.

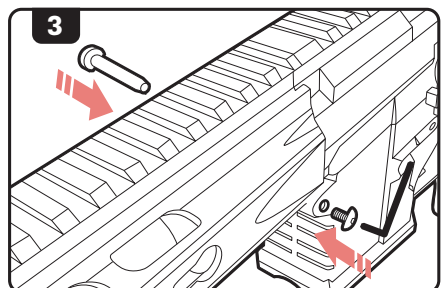
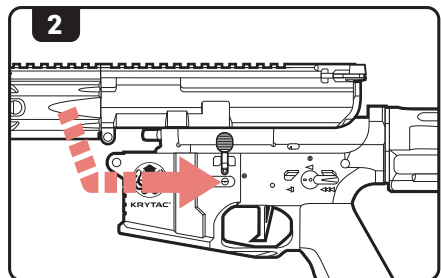
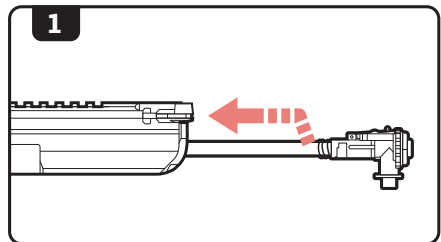

MAIN SPRING ACCESS



PLEASE REVIEW THE WARRANTY CARD INFORMATION BEFORE OPENING AND/OR MODIFYING THE KRYTAC AIRSOFT GUN.

1. Disassemble the airsoft gun. (see pg.11 for disassembly instructions).
2. Remove the bolt release button **(A)**.

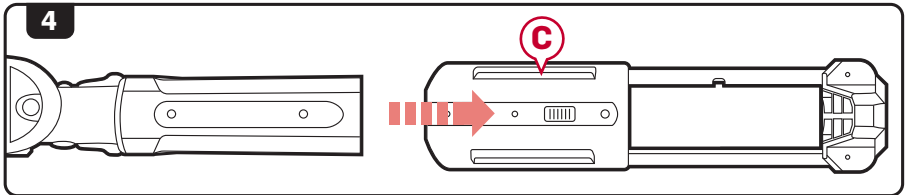
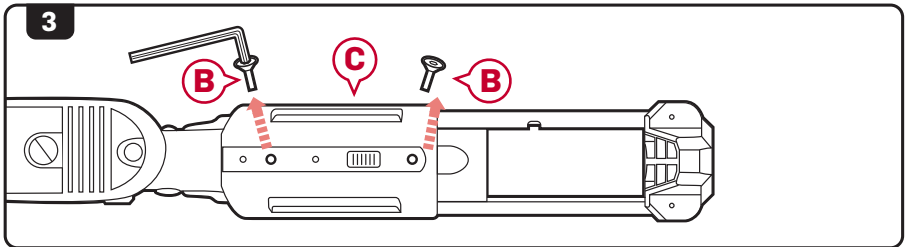
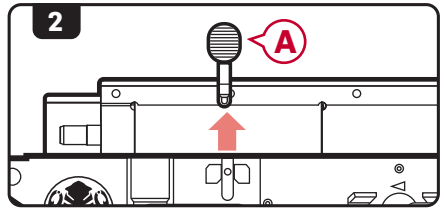

3. Use a 2.5 mm hex key to remove the 2 screws **(B)** at the bottom of the compact carbine stock **(C)**.
4. Remove the compact carbine stock **(C)**.
5. Use a Phillip (P3) screw driver to remove screw **(D)** from inside the buffer tube **(E)**.
6. Remove the buffer tube **(E)**.
7. Remove the sling plate **(F)**.

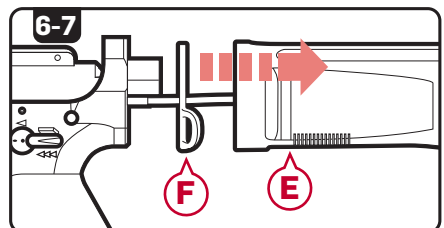
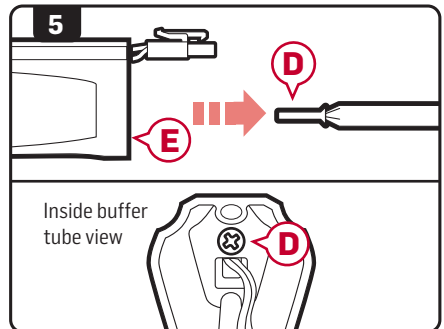

MAIN SPRING ACCESS

8. Remove the screw **G** from the magazine release button **H** using a Phillip screw driver, then remove the magazine release button **H**.
9. Use a 3 mm hex key to remove the rear receiver pin screw **I**.
10. Use a Phillips screw driver to remove 2 screws **J** on the bottom of the motor plate **K** then remove the motor plate.

NOTE

Take note of the wire and motor orientation before disconnecting.

11. Disconnect the motor wires **L** and remove the motor **M**.
12. Remove 2 Phillips screws **N** at the top of the motor grip interior, then remove the motor grip **O**.

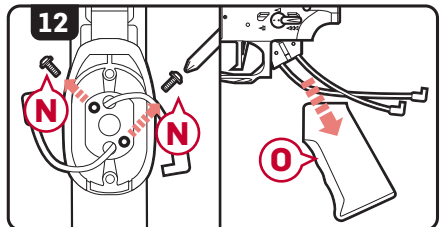
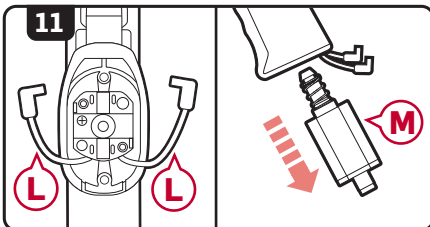
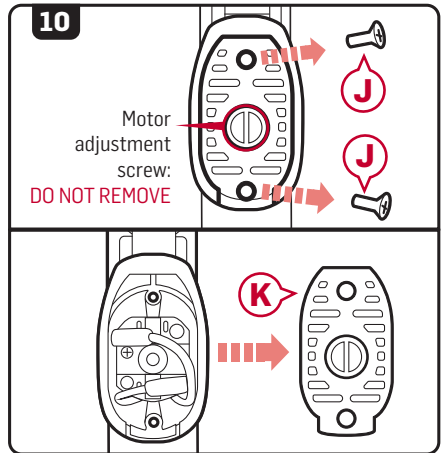
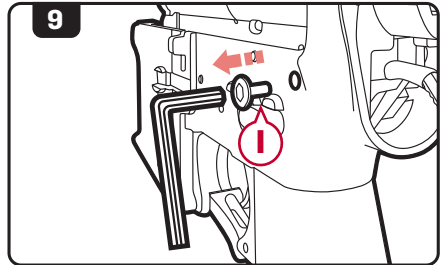
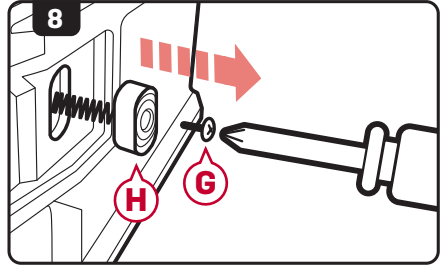

MAIN SPRING ACCESS

13. Remove the right side selector switch **P** using a 1.5 mm hex key.
14. Press the rear receiver pin **Q** in and remove it from the other side of the airsoft gun.
15. Use a 2.5 mm punch **R** and press the body pin **S** in and remove it from the other side of the airsoft gun.
16. Move the selector switch **T** half way between safe mode and semi-automatic mode then slide the gearbox **U** out of the lower receiver.
17. Use a flathead screwdriver **V** push the spring guide **W** into the gearbox, turn 90° counter clockwise then pull the spring guide and spring **X** out.

NOTE

Spring guide is under extreme pressure. Remove with caution.

18. Re-insert spring guide with desired spring into gear box. Follow steps in reverse order to reassemble the airsoft gun.

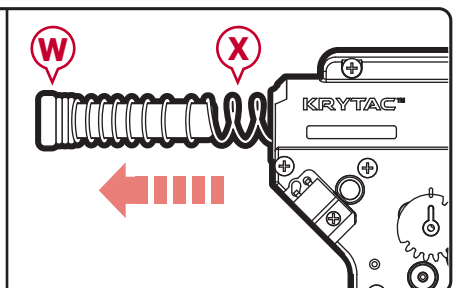
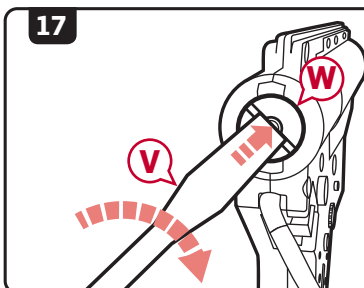
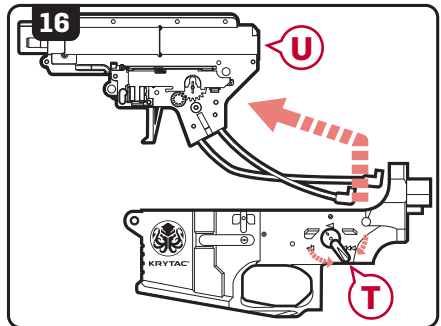
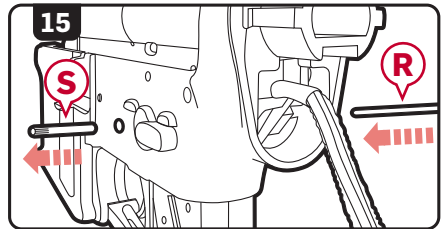
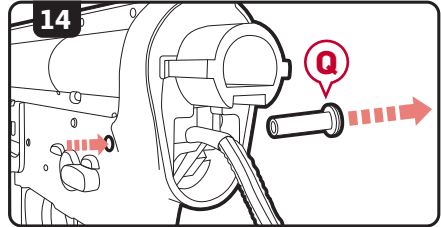
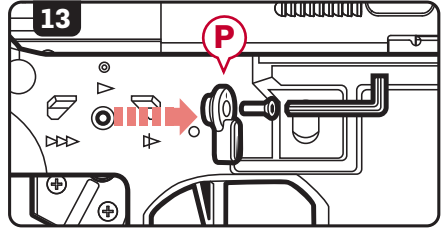

CLEANING AND MAINTENANCE

NOTE

WHILE POINTING THE AIRSOFT GUN IN A SAFE DIRECTION, REMOVE THE MAGAZINE AND CYCLE THE GEARBOX UNTIL NO BBS EXIT THE INNER BARREL. PLACE THE AIRSOFT GUN IN SAFE MODE AND DISCONNECT THE BATTERY PRIOR TO ANY CLEANING PROCEDURES.

1. Wipe down the external parts of the gun and remove any dirt and debris.
2. Disassemble the airsoft gun as described in the Disassembly section and pull out the barrel and hop-up assembly (A).
3. Pull back on the hop-up adjustment wheel (B) and lift the hop-up adjustment lever (C) up.
4. Take a lint-free cleaning patch (D) and place it through the looped end of the cleaning rod (E).

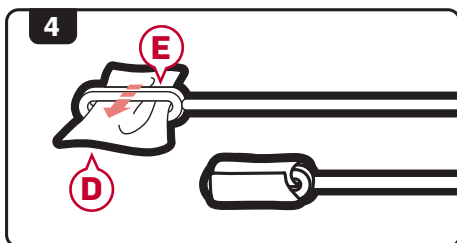
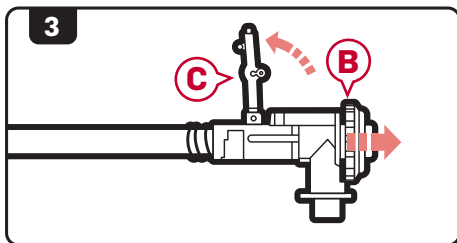
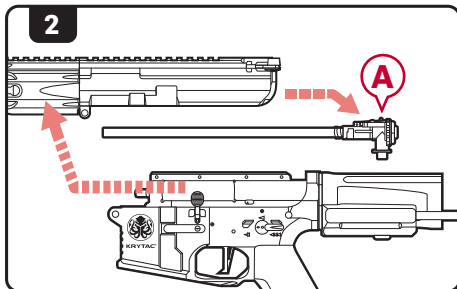
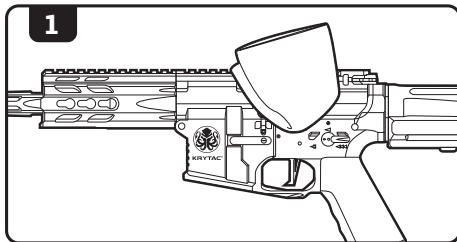

WARNING

DO NOT ADD OIL TO THE HOP-UP BUCKING. EXCESSIVE OIL ON THE HOP-UP BUCKING MAY NEGATE THE HOP-UP, DECREASING RANGE AND ACCURACY.

CLEANING AND MAINTENANCE

5. Run the cleaning rod through the barrel from back to front (in the same direction that BBs travel).

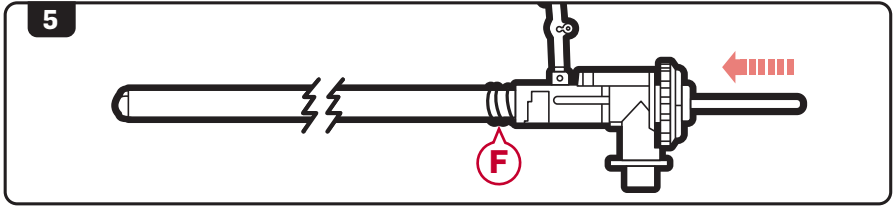

WARNING

KEEP TRACK OF THE BARREL SPRING (F), IT CAN SEPARATE FROM THE BARREL ASSEMBLY.

6. Pull back on the hop-up adjustment wheel and lower the hop-up adjustment lever back into position.
7. Reinsert the hop-up barrel assembly into the receiver and reassemble as described in the Assembly section.

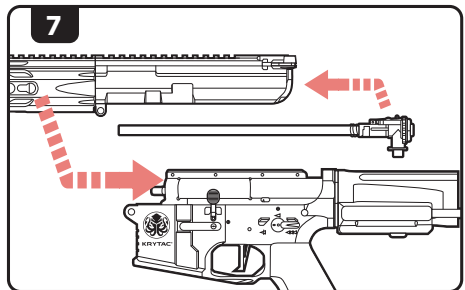
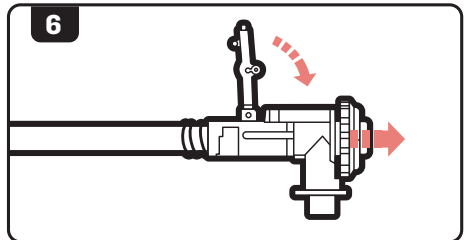

OPERATING UNDER HARSH CONDITIONS

When operating under harsh conditions, special maintenance may be required to match the climate conditions of a specific operational area.

Dust and Sand

In harsh dusty or sandy environments, excessive debris can cause malfunctions and/or excessive wear on parts. Keep the gun covered and protected while not in use. When performing maintenance, use lubrication sparingly as it tends to attract dirt and other particles. After use in a dusty or sandy area, always field strip the gun, as outlined in the Disassembly section, cleaning all the areas that can be reached with a soft, clean, lint-free cloth.

Heavy Rain

Never submerge or expose your gun to extremely wet environments. Exposure to such conditions may cause electrical failure and fluid to build-up inside the gearbox. Dry completely with a clean, lint-free cloth and clean inner barrel when necessary.

TROUBLE SHOOTING GUIDE



WARNING

WHEN TROUBLESHOOTING, FOLLOW THE SAFETY MEASURES DESCRIBED IN THIS MANUAL.

SYMPTOMS	CAUSE	SOLUTIONS
Not firing/No sound	Safety is engaged	Change selector to Semi Auto or Full Automatic Mode
	Low power or dead battery	Charge and replace battery
	Blown out fuse	Replace with new fuse
	Loose connection	Contact customer service for professional care
Motor is running but not firing	Inspect magazine	Check if magazine is properly loaded into the gun Ensure magazine is loaded with ammunition Ensure the hi-cap magazine is properly wound
Motor or battery is hot after short use	Damaged battery	Inspect and/or replace battery
	Loose connection terminal	Contact customer service for professional care
Semi-Auto feature not functioning properly	Battery voltage or discharge is too high	Condition or replace battery
Semi-Auto feature not working at all	Disconnecter is not engaged properly	Reset the disconnecter by setting the selector to safe, then to automatic, then to semi
Firing cycle slowing down	Battery is low on power	Charge or replace battery
High pitch or grinding noise	Motor level is not adjusted properly	Contact customer service for professional care
BB travels upward	Hop-up adjusted too high	Dial down the hop-up adjustment
BB travels downward	Hop-up adjusted too low	Dial up the hop-up adjustment
BB double feeding or rolling out of the barrel	Excessive grease or oil in the hopup chamber	Fire at least 200 rounds to eliminate excessive grease from the chamber Clean hop-up unit with supplied cleaning rod
	Hop-up unit is turned off	Turn hop-up unit on
Hop-up unit can't be adjusted	Hop-up adjustment arm is not set properly	Reset hop-up adjustment arm (See page 17, step 6 for reassembly)
Inner barrel is jammed or jamming	Use of recycled or low quality BBs	Use only KRYTAC branded or other high quality BBs
	Inner Barrel is contaminated with BBs or debris	Clear and/or clean inner barrel with supplied cleaning rod (See page 10 for clearing jam section and page 16 for cleaning and maintenance section)
Hi-Cap magazine not feeding	Magazine has not been wound	Wind wheel underneath magazine
	BBs are lodged inside the magazine	Shake or tap magazine to clear the jam
	Internal obstruction	Contact customer service for professional care

HEARING PROTECTION REQUIREMENT

HEARING PROTECTION REQUIREMENT FOR EUROPEAN COMMUNITY

The KRYTAC TRIDENT MK II PDW fulfills all relevant provisions of:

EMC Directive (2014/30/EU)
RoHS Directive (2011/65/EU)
General Product Safety Directive (2001/95/EC)

In conjunction with the following harmonized standards or technical specifications for the design and manufacture

EN 50581:2012; EN 55014-1:2006; EN 55014-2:1997

In accordance with the above mentioned standards, in some applications, noise or vibration levels may exceed the minimum Noise levels of 85db(A). If Noise levels exceed 85dB(A), appropriate ear protection must be used to prevent any damages due to sound emissions.

CONTACT INFORMATION

Submit a contact form at: www.krytac.com

Email us at: support@krytac.com

Join the KRYTAC Community and visit <http://forums.krytac.com> for any additional technical questions and information about your KRYTAC.

COMPONENT DIAGRAM: PDW

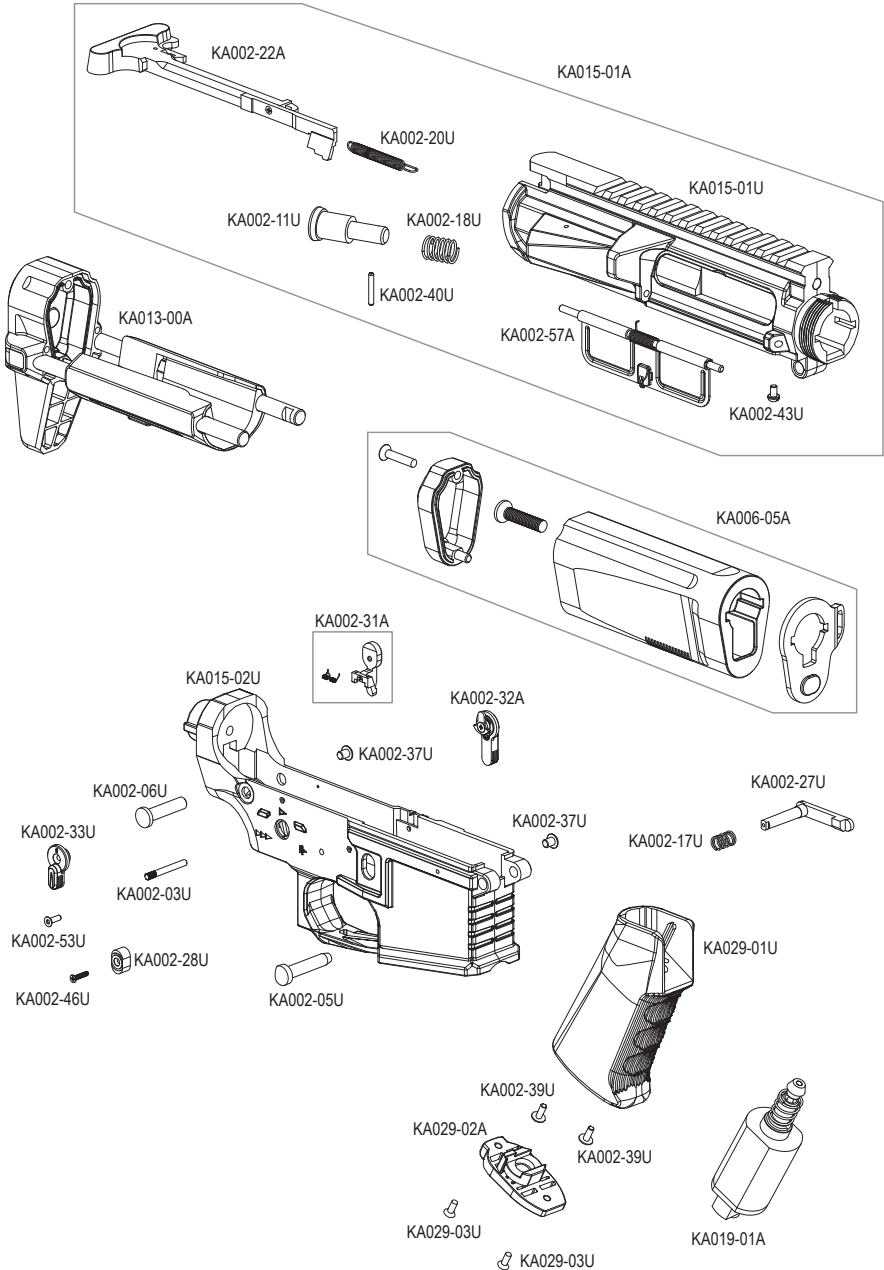

COMPONENT DIAGRAM: PDW

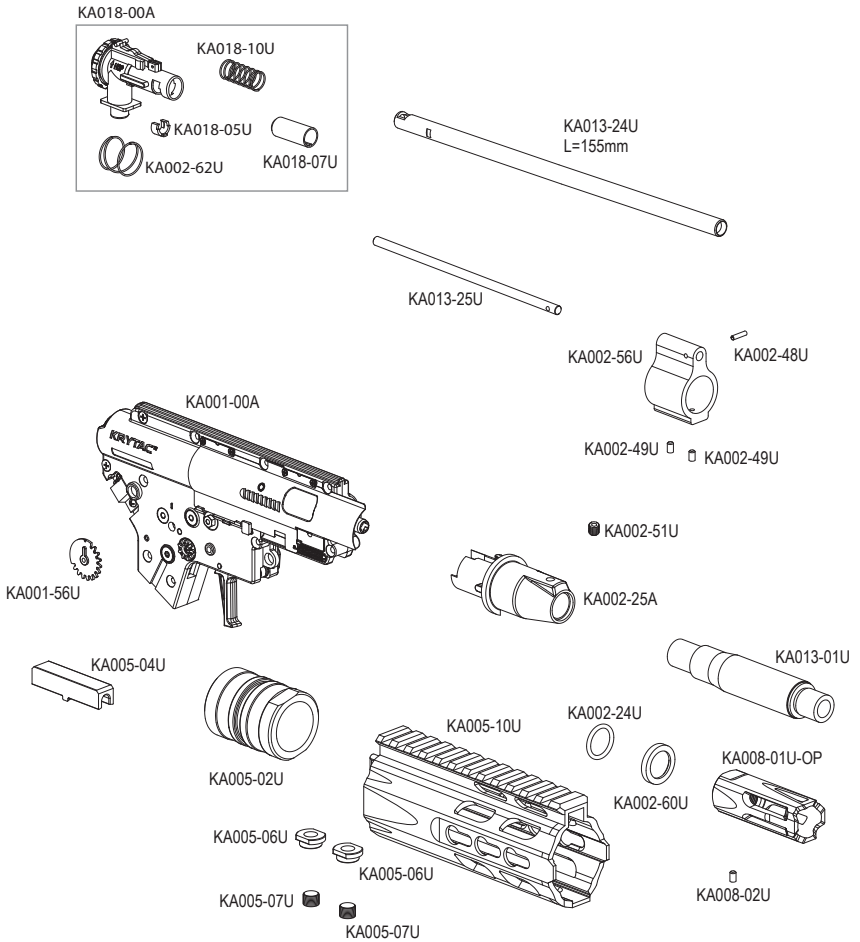

COMPONENT DIAGRAM: GEARBOX

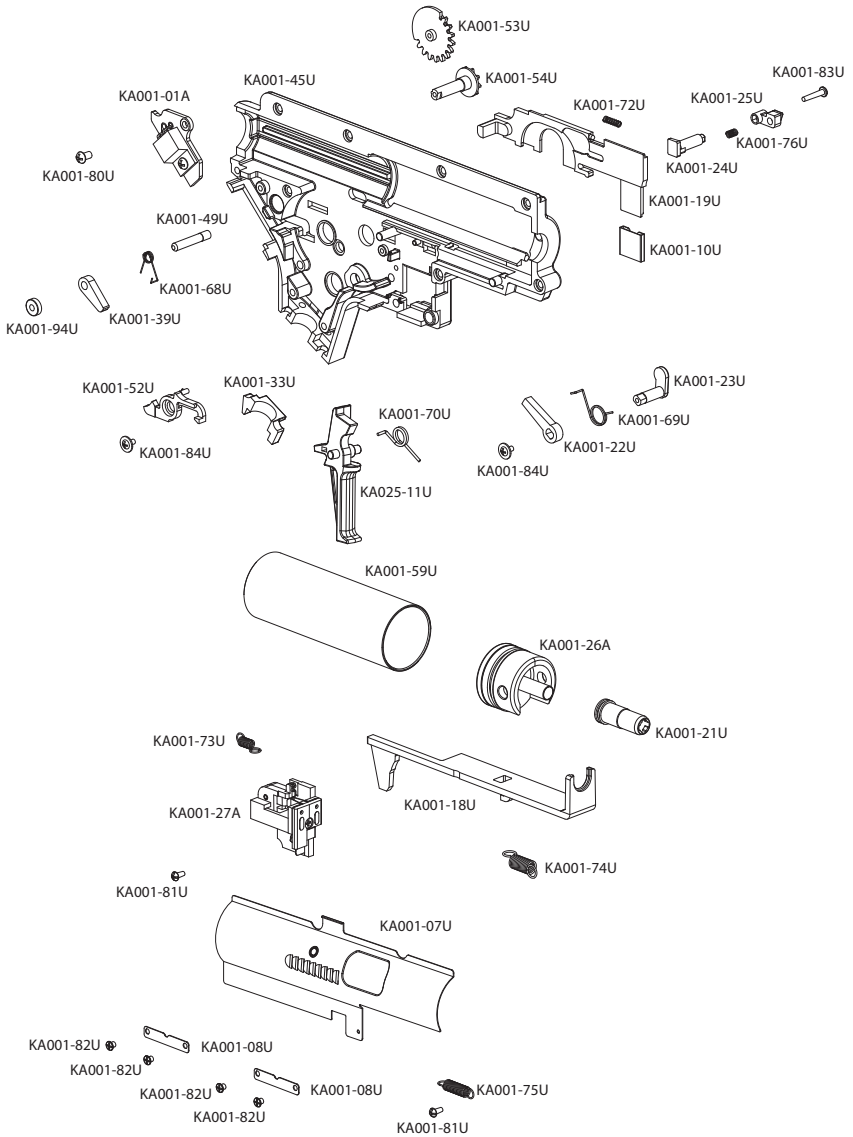

COMPONENT LIST: MK II PDW

PART #	NAME		
KA001-00A	GEARBOX	KA001-55U	SELECTOR TRANSFER CAP GEAR
KA001-01A	MOSFET ASSEMBLY	KA001-56U	SELECTOR GEAR (RIGHT)
KA001-03A	SECTOR GEAR	KA001-57U	PISTON HEAD NUT
KA001-04A	SPUR GEAR	KA001-59U	CYLINDER (TYPE 1)
KA001-05A	BEVEL GEAR	KA001-60A	SPRING GUIDE ASSEMBLY
KA001-07U	BOLT PLATE	KA001-68U	ANTI-REVERSE LATCH SPRING
KA001-08U	BOLT PLATE GUIDE (2)	KA001-69U	SAFETY BLOCK SPRING
KA001-10U	CONTACT (SELECTOR)	KA001-70U	TRIGGER SPRING
KA001-15U	MAIN SPRING SHIM	KA001-71U	MAIN SPRING
KA001-16U	PISTON HEAD O-RING	KA001-72U	DISCONNECT SPRING
KA001-17U	PISTON HEAD SHIM	KA001-73U	SWITCH SPRING (M120)
KA001-18U	TAPPET PLATE	KA001-74U	TAPPET PLATE SPRING
KA001-19U	SELECTOR PLATE	KA001-75U	BOLT RETURN SPRING
KA001-21U	AIR NOZZLE	KA001-76U	BOLT PLATE LOCK SPRING
KA001-22U	SAFETY BLOCK	KA001-80U	MOSFET SCREW
KA001-23U	SAFETY BLOCK LEVER	KA001-81U	BUTTON MICRO SCREW
KA001-24U	BOLT PLATE LOCK	KA001-82U	BOLT PLATE SCREW (4)
KA001-25U	BOLT PLATE LOCK BUTTON	KA001-83U	BOLT PLATE LOCK SCREW
KA001-26A	CYLINDER HEAD ASSEMBLY	KA001-84U	FLAT MICRO SCREW (2)
KA001-27A	SWITCH ASSEMBLY	KA001-85U	SELECTOR TRANSFER GEAR SCREW
KA001-31A	PISTON ASSEMBLY	KA001-86U	GEARBOX SHELL SCREW (LONG)(6)
KA001-31U	PISTON	KA001-87U	GEARBOX SHELL SCREW (SHORT)(4)
KA001-32U	PISTON HEAD	KA001-88U	PISTON HEAD SCREW
KA001-33U	WIRING COVER	KA001-94U	SOLID STEEL BUSHING
KA001-35U	SHIM (6)	KA002-03U	GEARBOX PIN
KA001-37U	BEARING (6)	KA002-05U	FRONT RECEIVER PIN
KA001-39U	ANTI-REVERSE LATCH	KA002-06U	REAR RECEIVER PIN
KA001-40U	PISTON TOOTH RACK	KA002-11U	FORWARD ASSIST BUTTON
KA001-44U	GEARBOX SHELL (RIGHT)	KA002-17U	MAGAZINE RELEASE SPRING
KA001-45U	GEARBOX SHELL (LEFT)	KA002-18U	FORWARD ASSIST SPRING
KA001-49U	ANTI-REVERSE LATCH PIN	KA002-20U	CHARGING HANDLE SPRING
KA001-52U	DISCONNECT LEVER	KA002-22A	CHARGING HANDLE ASSEMBLY
KA001-53U	SELECTOR GEAR (LEFT)		
KA001-54U	SELECTOR TRANSFER AXIS GEAR		

COMPONENT LIST: MK II PDW

KA002-24U	CRUSH WASHER O-RING	KA015-01U	UPPER RECEIVER
KA002-25U	OUTER BARREL BASE	KA015-02U	LOWER RECEIVER
KA002-27U	MAGAZINE RELEASE	KA018-01A	HOP-UP UNIT ASSEMBLY
KA002-28U	MAGAZINE RELEASE BUTTON	KA018-05U	BARREL CLIP
KA002-31A	BOLT STOP ASSEMBLY	KA018-07U	BUCKING
KA002-32A	LEFT SELECTOR ASSEMBLY	KA018-10U	TENSION SPRING
KA002-33U	RIGHT SELECTOR	KA019-01A	MOTOR
KA002-37U	RECEIVER PIN CAP SCREW (2)	KA025-13U	MAIN SPRING (M95)
KA002-39U	PISTOL GRIP SCREW (2)	KA029-01U	PISTOL GRIP
KA002-40U	FORWARD ASSIST PIN	KA029-02A	MOTOR PLATE ASSEMBLY
KA002-43U	CHARGING HANDLE ANCHOR SCREW	KA029-07U	MOTOR PLATE SCREW (2)
KA002-46U	MAGAZINE RELEASE SCREW		
KA002-48U	GAS BLOCK PIN		
KA002-49U	GAS BLOCK SCREWS (2)		
KA002-51U	OUTER BARREL BASE SCREW		
KA002-53U	RIGHT SELECTOR SCREW		
KA002-56U	GAS BLOCK		
KA002-57A	DUST COVER ASSEMBLY		
KA002-60U	CRUSH WASHER		
KA002-62U	HOP-UP OUTER TENSION SPRING		
KA005-02U	BARREL NUT		
KA005-04U	RAIL KEY		
KA005-06U	RETENSION NUT (2)		
KA005-07U	RETENSION SCREW (2)		
KA005-10U	RAIL 5 INCH		
KA006-05A	SDP BUFFER ASSEMBLY		
KA008-01U	FLASH HIDER		
KA008-02U	SET SCREW		
KA013-00A	COMPACT CARBINE STOCK (CCS)		
KA013-01U	PDW OUTER BARREL		
KA013-24U	INNER BARREL (155MM)		
KA013-25U	PDW GAS TUBE		
KA015-01A	UPPER RECEIVER ASSEMBLY		

www.krytac.com

© Copyright 2016
KRISS INDUSTRIES ASIA
Subject to change

V.03 R.2020.03.12

